

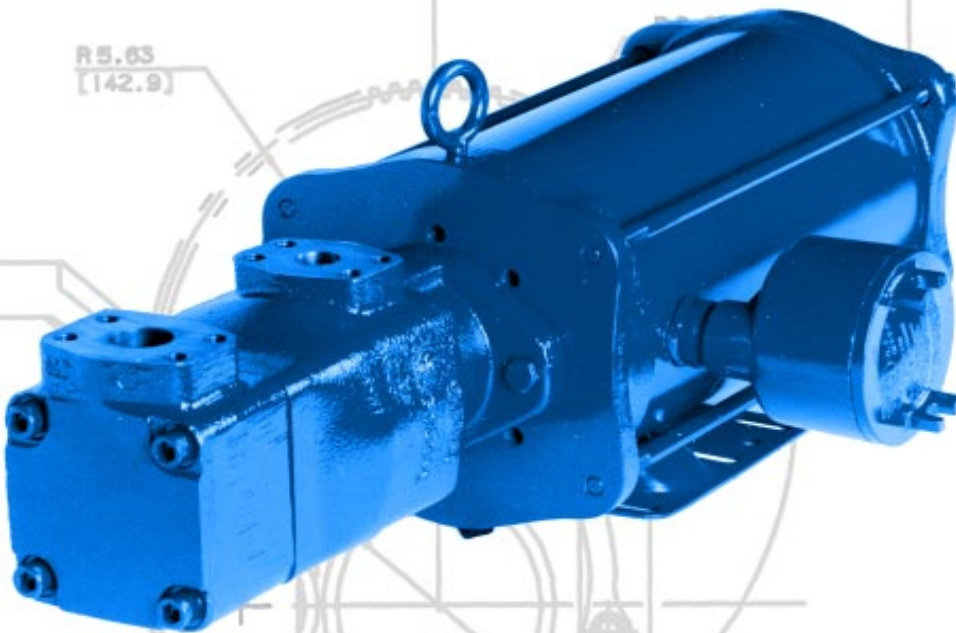

3E AND 110H/210H SERIES CANNED MOTOR PUMPS



***ROTARY SCREW PUMPS
WITH CANNED INTEGRAL MOTORS***

The reliable pump people

NOMINAL FLOW RANGE

SEE APPLICABLE PUMP BROCHURE FOR CONSTRUCTION DETAILS

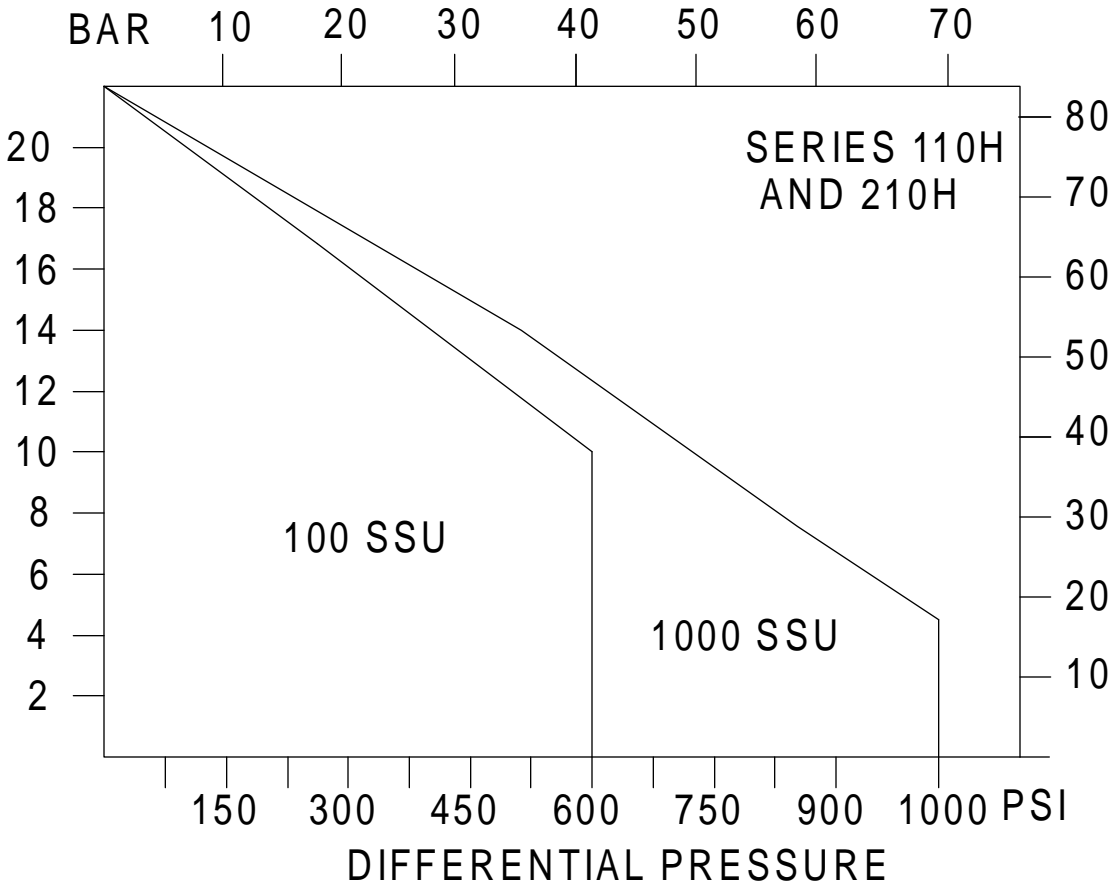
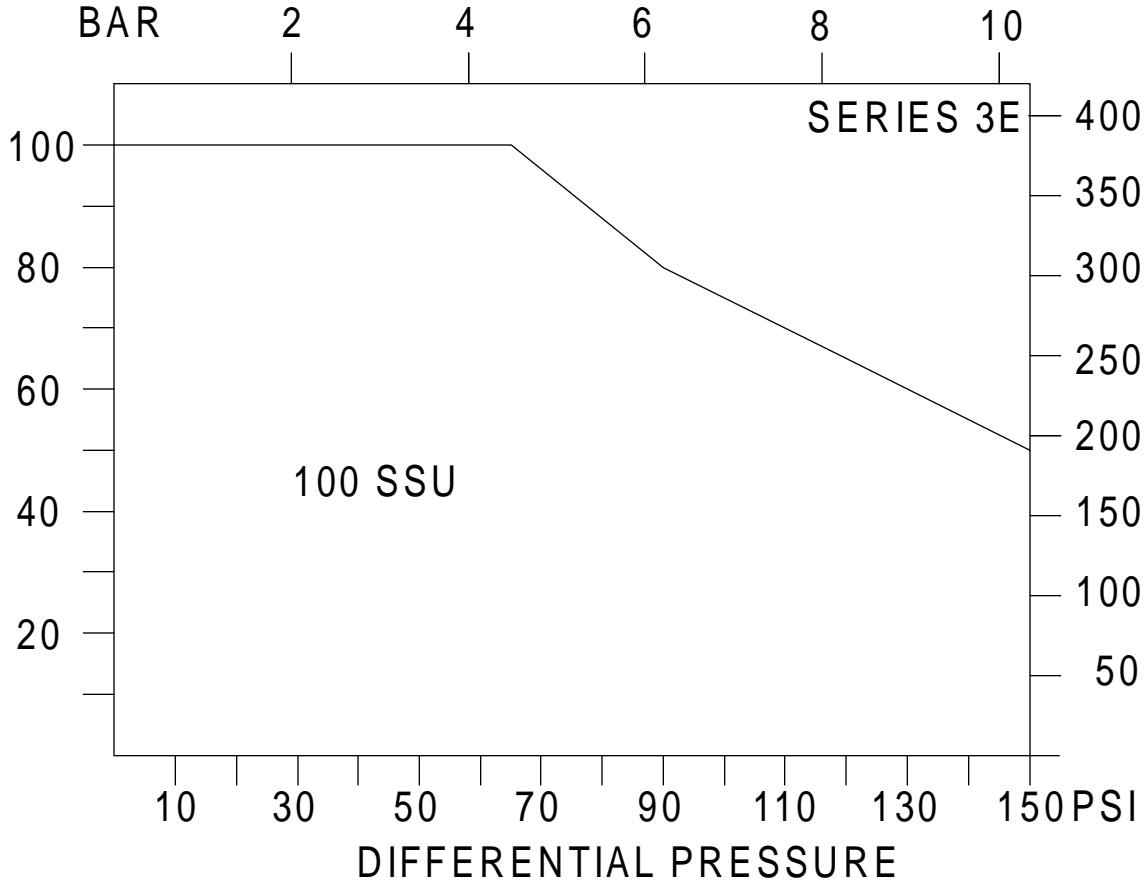

3E and 110H/210H Series Canned Motor Pumps

The new 3E and 110H/210H series canned motor pump designs from Imo Pump eliminate the need for shaft seals while providing ultra-smooth, pulsation free output flow from a positive displacement 3-screw pump. This integral pump and motor is cooled by the process fluid, eliminating the need for external air cooling fans which add to airborne noise levels. The result is a highly reliable integral pump and wet stator combination with airborne noise levels less than 60 dB(A) at three feet. The package is suitable for a wide range of lube and hydraulic oils applications at pressures up to 1000 psi (69 Bar) across a broad range of viscosities at fluid temperatures from 0 to 240°F (-18 to 115°C). Maximum inlet pressure to these pumps is 50 psig (3.45 barg). The wet stator design means no derating for altitudes above 3300 feet (1000 meters) and a smaller, more compact design. Motors are available for 2 to 6 Hp (1.5 TO 4.5 Kw) at 60 Hz and 1-1/2 to 5 HP (1.1 to 3.7 Kw) at 50 Hz.

For alternate fluid types, viscosities, temperatures, pressures or power supply different than those listed, please consult your local Imo Pump representative.

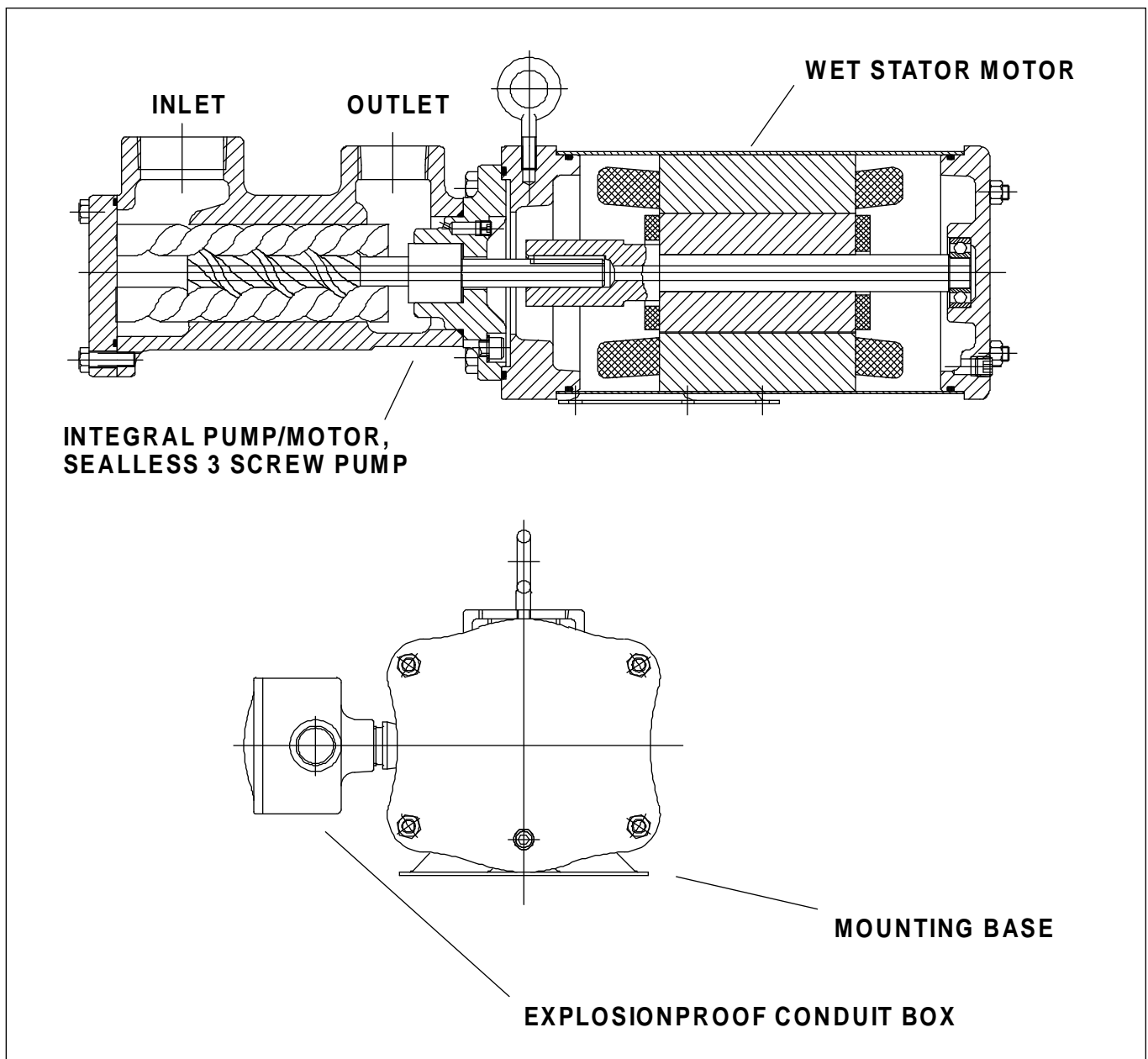

Motor Description and Ratings

The motors are of the wet stator, squirrel cage induction design available in 2-pole and 4-pole configurations. All sizes are single voltage, 3-phase. There are no construction differences between the 50 Hz and the 60 Hz motors. Motor output power and speed will depend on input power voltage and frequency. *All motors are name plated with their nominal characteristics regardless of actual service as specified or installed.* Motors have an internal ball bearing at the non-drive end lubricated by the fluid pumped. These motors may be mounted in any attitude.

Standard Materials of Construction

Frame with mounting foot	Welded carbon steel
End covers	Cast iron
Shaft/rotor assembly	Carbon steel
Stator windings	Copper with class F insulation
Conduit box	Aluminum
Wire connections	16 gauge, stranded copper, teflon insulated
O-rings	Per model code: Viton, Buna N, Neoprene or special

Maximum Fluid Temperature 240°F (115°C)

Power Ratings (applies regardless of altitude)

Motor size designation:	02	03	05	06
HP (Kw) at 230 or 460 volt, 60 Hz, 3 phase	2.0 (1.49)	3.0 (2.24)	5.0 (3.72)	6.0 (4.47)
HP (Kw) at 220 or 380 volt, 50 Hz, 3 phase	1.5 (1.12)	2.0 (1.49)	3.0 (2.24)	5.0 (3.72)

Nominal Full Load Speeds

2-pole, 60 Hz	3450 RPM
4-pole, 60 Hz	1725 RPM
2-pole, 50 Hz	2850 RPM
4-pole, 50 Hz	1425 RPM

Time Rating Continuous duty

Ambient Temperature Rating 104°F (40°C)

Enclosure Not formally rated

3E & 110H/210H CANNED MOTOR PUMP

MODEL DESIGNATOR

W 02 C 003E 118 SC 460 C V 00

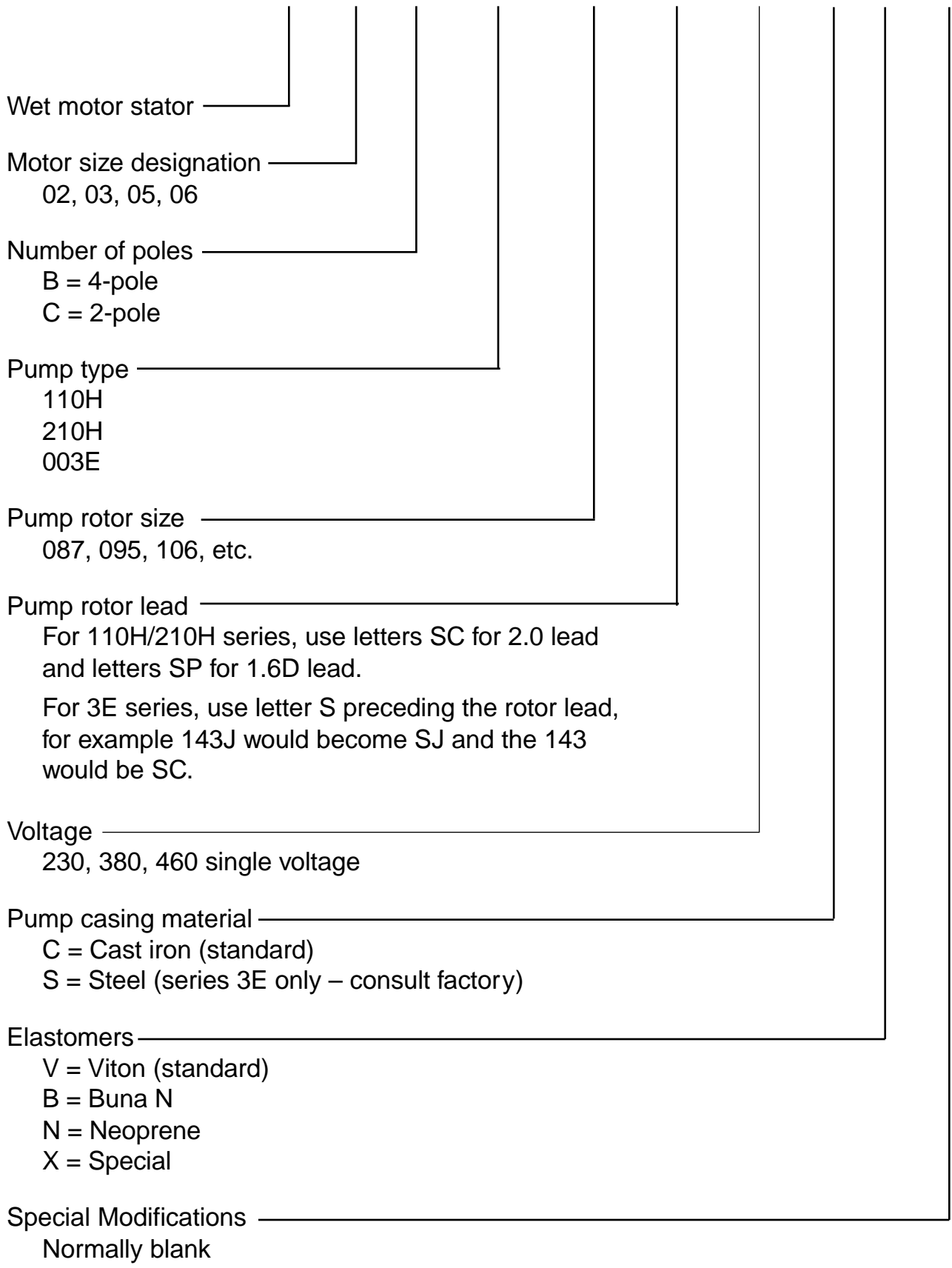

SERIES 3E

Pump Rotor Size 87P									
Speed 3450 RPM (60 Hz 2-pole)									
Viscosity SSU	Differential Pressure PSID								
	25	50	100	150					
M P L G	33	4.9	4.3	3.4	2.8	L	*		
	65	5.3	4.9	4.3	3.8				
	100	5.5	5.2	4.7	4.3				
	650	6.0	5.9	5.7	5.6				
	1000	6.1	6.0	5.8	5.7				
R H B	1500	6.2	6.1	5.9	5.8	—	S		
	150	0.26	0.36	0.57	0.78			Z	D
	650	0.49	0.60	0.80	1.0				
	1000	0.61	0.71	0.92	1.1				
1500	0.75	0.86	1.1	1.3					

Pump Rotor Size 87									
Speed 3450 RPM (60 Hz 2-pole)									
Viscosity SSU	Differential Pressure PSID								
	25	50	100	150					
M P L G	33	6.7	6.1	5.2	4.6	L	*		
	65	7.1	6.7	6.1	5.6				
	100	7.3	7.0	6.5	6.1				
	650	7.8	7.7	7.5	7.4				
	1000	7.9	7.8	7.6	7.5				
R H B	1500	8.0	7.8	7.7	7.6	—	S		
	150	0.29	0.42	0.68	0.94			Z	D
	650	0.52	0.65	0.91	1.2				
	1000	0.64	0.76	1.0	1.3				
1500	0.78	0.91	1.2	1.4					

Pump Rotor Size 87P									
Speed 2850 RPM (50 Hz 2-pole)									
Viscosity SSU	Differential Pressure PSID								
	25	50	100	150					
M P L G	33	3.7	3.0	N/A	N/A	L	*		
	65	4.1	3.6	3.0	2.6				
	100	4.3	3.9	3.5	3.1				
	650	4.8	4.7	4.5	4.3				
	1000	4.9	4.8	4.6	4.5				
R H B	1500	4.9	4.8	4.7	4.6	—	S		
	150	0.19	0.28	0.45	0.62			Z	D
	650	0.35	0.44	0.61	0.78				
	1000	0.43	0.52	0.69	0.86				
1500	0.53	0.62	0.79	0.96					

Pump Rotor Size 87									
Speed 2850 RPM (50 Hz 2-pole)									
Viscosity SSU	Differential Pressure PSID								
	25	50	100	150					
M P L G	33	5.2	4.5	3.7	N/A	L	*		
	65	5.6	5.1	4.5	4.0				
	100	5.8	5.4	4.9	4.6				
	650	6.3	6.2	6.0	5.8				
	1000	6.4	6.2	6.1	6.0				
R H B	1500	6.4	6.3	6.2	6.1	—	S		
	150	0.21	0.32	0.54	0.75			Z	D
	650	0.37	0.48	0.70	0.91				
	1000	0.45	0.56	0.78	0.99				
1500	0.55	0.66	0.88	1.1					

Pump Rotor Size 87P									
Speed 1725 RPM (60 Hz 4-pole)									
Viscosity SSU	Differential Pressure PSID								
	25	50	100	150					
M P L G	33	N/A	N/A	N/A	N/A	L	*		
	65	1.8	N/A	N/A	N/A				
	100	2.0	N/A	N/A	N/A				
	650	2.5	2.4	2.2	2.0				
	1000	2.6	2.4	2.3	2.2				
R H B	1500	2.6	2.5	2.4	2.3	—	S		
	150	0.09	N/A	N/A	N/A			Z	D
	650	0.15	0.20	0.31	0.41				
	1000	0.18	0.23	0.34	0.44				
1500	0.22	0.27	0.37	0.48					

Pump Rotor Size 87									
Speed 1725 RPM (60 Hz 4-pole)									
Viscosity SSU	Differential Pressure PSID								
	25	50	100	150					
M P L G	33	N/A	N/A	N/A	N/A	L	*		
	65	2.7	2.2	N/A	N/A				
	100	2.9	2.5	N/A	N/A				
	650	3.4	3.2	3.0	2.9				
	1000	3.4	3.3	3.2	3.1				
R H B	1500	3.5	3.4	3.3	3.2	—	S		
	150	0.10	0.16	N/A	N/A			Z	D
	650	0.16	0.23	0.36	0.49				
	1000	0.19	0.26	0.39	0.52				
1500	0.23	0.30	0.43	0.56					

Pump Rotor Size 87P									
Speed 1425 RPM (50 Hz 4-pole)									
Viscosity SSU	Differential Pressure PSID								
	25	50	100	150					
M P L G	33	N/A	N/A	N/A	N/A	L	*		
	65	N/A	N/A	N/A	N/A				
	100	1.4	N/A	N/A	N/A				
	650	1.9	1.7	1.5	1.4				
	1000	1.9	1.8	1.7	1.5				
R H B	1500	2.0	1.9	1.8	1.7	—	S		
	150	0.07	N/A	N/A	N/A			Z	D
	650	0.11	0.15	0.24	0.33				
	1000	0.13	0.17	0.26	0.35				
1500	0.16	0.20	0.29	0.37					

Pump Rotor Size 87									
Speed 1425 RPM (50 Hz 4-pole)									
Viscosity SSU	Differential Pressure PSID								
	25	50	100	150					
M P L G	33	N/A	N/A	N/A	N/A	L	*		
	65	1.9	N/A	N/A	N/A				
	100	2.1	N/A	N/A	N/A				
	650	2.6	2.5	2.3	2.1				
	1000	2.7	2.6	2.4	2.3				
R H B	1500	2.7	2.6	2.5	2.4	—	S		
	150	0.08	N/A	N/A	N/A			Z	D
	650	0.12	0.18	0.28	0.39				
	1000	0.14	0.20	0.30	0.41				
1500	0.17	0.22	0.33	0.44					

 indicates exceeds current motor size availability N/A=not applicable
 * Net inlet pressure required is the minimum pressure above vapor pressure at pump inlet to prevent cavitation assuming liquid is air and gas free.

SERIES 3E

Pump Rotor Size 95							
Speed 3450 RPM (60 Hz 2-pole)							
Viscosity SSU	Differential Pressure PSID						
	25	50	100	150			
G P M	33	8.9	8.2	7.2	6.4	P L S P Z	* — — — —
	65	9.4	8.9	8.2	7.6		
	100	9.7	9.3	8.7	8.2		
	650	10.3	10.1	9.9	9.7		
	1000	10.4	10.2	10.0	9.9		
1500	10.4	10.3	10.2	10.0			
P H B	150	0.37	0.53	0.87	1.2	4.8	
	650	0.66	0.83	1.2	1.5	5.0	
B	1000	0.81	0.98	1.3	1.6	5.1	
	1500	1.0	1.2	1.5	1.8	5.3	

Pump Rotor Size 118P							
Speed 3450 RPM (60 Hz 2-pole)							
Viscosity SSU	Differential Pressure PSID						
	25	50	100	150			
G P M	33	14.4	13.2	11.6	10.5	P L S P Z	* — — — —
	65	15.2	14.4	13.2	12.4		
	100	15.5	14.9	14.0	13.3		
	650	16.5	16.2	15.9	15.6		
	1000	16.6	16.4	16.1	15.9		
1500	16.7	16.5	16.3	16.1			
P H B	150	0.65	0.91	1.4	2.0	4.8	
	650	1.2	1.5	2.0	2.5	5.0	
B	1000	1.5	1.8	2.3	2.8	5.1	
	1500	1.9	2.1	2.7	3.2	5.3	

Pump Rotor Size 95							
Speed 2850 RPM (50 Hz 2-pole)							
Viscosity SSU	Differential Pressure PSID						
	25	50	100	150			
G P M	33	6.9	6.2	5.2	N/A	P L S P Z	* — — — —
	65	7.4	6.9	6.2	5.6		
	100	7.7	7.3	6.7	6.2		
	650	8.3	8.1	7.9	7.7		
	1000	8.4	8.2	8.0	7.9		
1500	8.4	8.3	8.2	8.0			
P H B	150	0.27	0.41	0.69	0.96	4.4	
	650	0.48	0.61	0.90	1.2	4.6	
B	1000	0.58	0.72	0.99	1.3	4.7	
	1500	0.71	0.84	1.1	1.4	4.8	

Pump Rotor Size 118P							
Speed 2850 RPM (50 Hz 2-pole)							
Viscosity SSU	Differential Pressure PSID						
	25	50	100	150			
G P M	33	11.3	10.2	8.6	7.4	P L S P Z	* — — — —
	65	12.1	11.3	10.1	9.3		
	100	12.4	11.8	10.9	10.2		
	650	13.4	13.1	12.8	12.5		
	1000	13.5	13.3	13.0	12.8		
1500	13.6	13.4	13.2	13.0			
P H B	150	0.48	0.7	1.1	1.6	4.4	
	650	0.88	1.1	1.5	2	4.6	
B	1000	1.1	1.3	1.7	2.2	4.7	
	1500	1.3	1.5	2.0	2.4	4.8	

Pump Rotor Size 95							
Speed 1725 RPM (60 Hz 4-pole)							
Viscosity SSU	Differential Pressure PSID						
	25	50	100	150			
G P M	33	3.2	2.5	N/A	N/A	P L S P Z	* — — — —
	65	3.7	3.2	N/A	N/A		
	100	4.0	3.6	3.0	N/A		
	650	4.6	4.4	4.2	4.0		
	1000	4.6	4.5	4.3	4.2		
1500	4.7	4.6	4.4	4.3			
P H B	150	0.13	0.22	0.38	N/A	3.9	
	650	0.21	0.29	0.46	0.63	4.0	
B	1000	0.25	0.33	0.50	0.66	4.0	
	1500	0.29	0.38	0.54	0.71	4.1	

Pump Rotor Size 118P							
Speed 1725 RPM (60 Hz 4-pole)							
Viscosity SSU	Differential Pressure PSID						
	25	50	100	150			
G P M	33	5.5	4.3	N/A	N/A	P L S P Z	* — — — —
	65	6.2	5.4	N/A	N/A		
	100	6.6	6.0	5.1	4.4		
	650	7.6	7.3	7.0	6.7		
	1000	7.7	7.5	7.2	7.0		
1500	7.8	7.6	7.4	7.2			
P H B	150	0.23	0.36	0.62	0.88	3.9	
	650	0.34	0.51	0.77	1.0	4.0	
B	1000	0.45	0.58	0.84	1.1	4.0	
	1500	0.54	0.67	0.93	1.2	4.1	

Pump Rotor Size 95							
Speed 1425 RPM (50 Hz 4-pole)							
Viscosity SSU	Differential Pressure PSID						
	25	50	100	150			
G P M	33	2.2	N/A	N/A	N/A	P L S P Z	* — — — —
	65	2.7	2.2	N/A	N/A		
	100	3.0	2.6	N/A	N/A		
	650	3.6	3.4	3.2	3.0		
	1000	3.7	3.5	3.3	3.2		
1500	3.7	3.6	3.4	3.3			
P H B	150	0.10	0.17	0.31	N/A	3.8	
	650	0.16	0.22	0.36	0.50	3.8	
B	1000	0.18	0.25	0.39	0.53	3.9	
	1500	0.21	0.28	0.42	0.56	3.9	

Pump Rotor Size 118P							
Speed 1425 RPM (50 Hz 4-pole)							
Viscosity SSU	Differential Pressure PSID						
	25	50	100	150			
G P M	33	3.9	N/A	N/A	N/A	P L S P Z	* — — — —
	65	4.7	3.9	N/A	N/A		
	100	5.1	4.4	N/A	N/A		
	650	6.0	5.8	5.4	5.1		
	1000	6.1	5.9	5.6	5.4		
1500	6.2	6.1	5.8	5.6			
P H B	150	0.18	0.28	0.5	N/A	3.8	
	650	0.28	0.38	0.6	0.81	3.8	
B	1000	0.33	0.44	0.65	0.87	3.9	
	1500	0.39	0.50	0.71	0.93	3.9	

 indicates exceeds current motor size availability N/A=not applicable
 * Net inlet pressure required is the minimum pressure above vapor pressure at pump inlet to prevent cavitation assuming liquid is air and gas free.

SERIES 3E

Pump Rotor Size 118								
Speed 3450 RPM (60 Hz 2-pole)								
Viscosity SSU	Differential Pressure PSID							
	25	50	100	150				
G P M	33	18.8	17.7	16.1	14.9	P L *	S	
	65	19.6	18.8	17.7	16.8			
	100	20.0	19.4	18.4	17.7			
	650	20.9	20.7	20.3	20.1			
	1000	21.1	20.8	20.6	20.4			
B H P	1500	21.1	21.0	20.8	20.6	Z P		
	150	0.72	1.0	1.7	2.3			5.3
	650	1.3	1.60	2.30	2.9			5.7
	1000	1.6	1.9	2.6	3.2			6.0
B	1500	1.9	2.3	2.9	3.6		6.3	

Pump Rotor Size 143J								
Speed 3450 RPM (60 Hz 2-pole)								
Viscosity SSU	Differential Pressure PSID							
	25	50	100	150				
G P M	33	25.7	24.3	22.4	21.0	P L *	S	
	65	26.6	25.6	24.3	23.3			
	100	27.1	26.3	25.2	24.4			
	650	28.2	27.9	27.5	27.1			
	1000	28.3	28.1	27.7	27.5			
B H P	1500	28.4	28.3	28.0	27.7	Z P		
	150	1.1	1.6	2.4	3.3			5.1
	650	2.1	2.6	3.4	4.3			5.4
	1000	2.7	3.1	4.0	4.8			5.5
B	1500	3.3	3.7	4.6	5.5		5.8	

Pump Rotor Size 118								
Speed 2850 RPM (50 Hz 2-pole)								
Viscosity SSU	Differential Pressure PSID							
	25	50	100	150				
G P M	33	15.0	13.8	12.3	11.0	P L *	S	
	65	15.7	14.9	13.8	12.9			
	100	16.1	15.5	14.6	13.9			
	650	17.1	16.8	16.4	16.2			
	1000	17.2	17.0	16.7	16.5			
B H P	1500	17.3	17.1	16.9	16.7	Z P		
	150	0.54	0.81	1.3	1.9			4.8
	650	0.93	1.2	1.7	2.3			5.1
	1000	1.1	1.4	1.9	2.5			5.2
B	1500	1.4	1.6	2.2	2.7		5.4	

Pump Rotor Size 143J								
Speed 2850 RPM (50 Hz 2-pole)								
Viscosity SSU	Differential Pressure PSID							
	25	50	100	150				
G P M	33	20.5	19.2	17.3	15.8	P L *	S	
	65	21.4	20.5	19.1	18.1			
	100	21.9	21.1	20.0	19.2			
	650	23.0	22.7	22.3	21.0			
	1000	23.2	22.9	22.6	22.3			
B H P	1500	23.3	23.1	22.8	22.6	Z P		
	150	0.83	1.2	1.9	2.6			4.6
	650	1.5	1.9	2.6	3.3			4.8
	1000	1.9	2.2	3.0	3.7			5.0
B	1500	2.3	2.7	3.4	4.1		5.1	

Pump Rotor Size 118								
Speed 1725 RPM (60 Hz 4-pole)								
Viscosity SSU	Differential Pressure PSID							
	25	50	100	150				
G P M	33	7.7	6.6	N/A	N/A	P L *	S	
	65	8.5	7.7	6.5	N/A			
	100	8.8	8.2	7.3	6.6			
	650	9.8	9.5	9.2	8.9			
	1000	9.9	9.7	9.4	9.2			
B H P	1500	10.0	9.8	9.6	9.4	Z P		
	150	0.26	0.42	0.75	1.1			4.0
	650	0.41	0.57	0.90	1.2			4.2
	1000	0.48	0.65	0.97	1.3			4.2
B	1500	0.58	0.74	1.1	1.4		4.3	

Pump Rotor Size 143J								
Speed 1725 RPM (60 Hz 4-pole)								
Viscosity SSU	Differential Pressure PSID							
	25	50	100	150				
G P M	33	10.8	9.5	7.6	N/A	P L *	S	
	65	11.8	10.8	9.5	8.4			
	100	12.2	11.4	10.4	9.5			
	650	13.4	13.0	12.6	12.3			
	1000	13.5	13.2	12.9	12.6			
B H P	1500	13.6	13.4	13.1	12.9	Z P		
	150	0.39	0.61	1.0	1.5			4.0
	650	0.65	0.87	1.3	1.7			4.1
	1000	0.79	1.0	1.4	1.9			4.1
B	1500	0.95	1.2	1.6	2.0		4.2	

Pump Rotor Size 118								
Speed 1425 RPM (50 Hz 4-pole)								
Viscosity SSU	Differential Pressure PSID							
	25	50	100	150				
G P M	33	5.8	4.6	N/A	N/A	P L *	S	
	65	6.5	5.7	4.6	N/A			
	100	6.9	6.3	5.4	4.6			
	650	7.8	7.6	7.2	7.0			
	1000	8.0	7.8	7.5	7.3			
B H P	1500	8.1	7.9	7.7	7.5	Z P		
	150	0.20	0.34	0.6	0.87			3.9
	650	0.30	0.44	0.71	0.98			4.0
	1000	0.35	0.49	0.76	1.0			4.0
B	1500	0.42	0.55	0.82	1.1		4.1	

Pump Rotor Size 143J								
Speed 1425 RPM (50 Hz 4-pole)								
Viscosity SSU	Differential Pressure PSID							
	25	50	100	150				
G P M	33	8.3	6.9	N/A	N/A	P L *	S	
	65	9.2	8.2	6.9	N/A			
	100	9.6	8.9	7.8	6.9			
	650	10.8	10.5	10.0	9.7			
	1000	10.9	10.7	10.3	10.1			
B H P	1500	11.0	10.8	10.5	10.3	Z P		
	150	0.30	0.48	0.84	1.2			3.8
	650	0.48	0.66	1.0	1.4			3.9
	1000	0.57	0.75	1.1	1.5			4.0
B	1500	0.68	0.86	1.2	1.6		4.0	

 indicates exceeds current motor size availability N/A=not applicable
 * Net inlet pressure required is the minimum pressure above vapor pressure at pump inlet to prevent cavitation assuming liquid is air and gas free.

SERIES 3E

Pump Rotor Size 143							
Speed 3450 RPM (60 Hz 2-pole)							
Viscosity SSU	Differential Pressure PSID						
	25	50	100	150			
G P M	33	34.8	33.2	30.9	29.1	P L S Z	* — — Z
	65	36.0	34.8	33.2	31.9		
	100	36.5	35.6	34.2	33.2		
	650	37.9	37.5	37.0	36.6		
	1000	38.1	37.8	37.4	37.0		
	1500	38.2	38	37.6	37.4		
H P	150	1.3	1.8	3.0	4.2	6.2	
	650	2.3	2.90	4.0	5.2	6.8	
B	1000	2.8	3.4	4.5	5.7	7.2	
	1500	3.4	4.0	5.2	6.3	7.8	

Pump Rotor Size 162							
Speed 3450 RPM (60 Hz 2-pole)							
Viscosity SSU	Differential Pressure PSID						
	25	50	100	150			
G P M	33	52.1	49.2	46.2	44.0	P L S Z	* — — Z
	65	52.8	51.3	49.2	47.5		
	100	53.5	52.3	50.6	49.3		
	650	55.2	54.8	54.1	53.6		
	1000	55.5	55.1	54.6	54.1		
	1500	55.6	55.3	54.9	54.6		
H P	150	1.8	2.7	4.3	6.0	6.9	
	650	3.3	4.1	5.8	7.5	7.9	
B	1000	4.1	4.9	6.6	8.2	8.5	
	1500	5.0	5.8	7.5	9.2	9.5	

Pump Rotor Size 143							
Speed 2850 RPM (50 Hz 2-pole)							
Viscosity SSU	Differential Pressure PSID						
	25	50	100	150			
G P M	33	28.0	26.3	24.0	22.2	P L S Z	* — — Z
	65	29.1	27.9	26.3	25.0		
	100	29.6	28.7	27.4	26.3		
	650	31.0	30.7	30.1	29.7		
	1000	31.2	30.9	30.5	30.2		
	1500	31.3	31.1	30.8	30.5		
H P	150	0.95	1.4	2.4	3.3	5.3	
	650	1.7	2.1	3.1	4.0	5.7	
B	1000	2.0	2.5	3.4	4.4	6.0	
	1500	2.4	2.9	3.9	4.8	6.3	

Pump Rotor Size 162							
Speed 2850 RPM (50 Hz 2-pole)							
Viscosity SSU	Differential Pressure PSID						
	25	50	100	150			
G P M	33	41.4	39.3	36.3	34.0	P L S Z	* — — Z
	65	42.8	41.4	39.2	37.6		
	100	43.5	42.3	40.6	39.3		
	650	45.3	44.8	44.2	43.7		
	1000	45.5	45.2	44.6	44.2		
	1500	45.7	45.4	44.9	44.6		
H P	150	1.4	2.1	3.4	4.8	5.8	
	650	2.4	3.1	4.4	5.8	6.3	
B	1000	2.9	3.6	5.0	6.4	6.7	
	1500	3.5	4.2	5.6	7.0	7.1	

Pump Rotor Size 143							
Speed 1725 RPM (60 Hz 4-pole)							
Viscosity SSU	Differential Pressure PSID						
	25	50	100	150			
G P M	33	15.1	13.4	11.1	N/A	P L S Z	* — — Z
	65	16.2	15.0	13.4	12.1		
	100	16.8	15.8	14.5	13.4		
	650	18.1	17.8	17.2	16.8		
	1000	18.3	18.0	17.6	17.3		
	1500	18.4	18.2	17.8	17.6		
H P	150	0.46	0.75	1.3	1.9	4.3	
	650	0.72	1.0	1.6	2.2	4.4	
B	1000	0.86	1.1	1.7	2.3	4.5	
	1500	1.0	1.3	1.9	2.5	4.6	

Pump Rotor Size 162							
Speed 1725 RPM (60 Hz 4-pole)							
Viscosity SSU	Differential Pressure PSID						
	25	50	100	150			
G P M	33	22.8	20.6	17.7	15.4	P L S Z	* — — Z
	65	24.2	22.7	20.6	19.0		
	100	24.9	23.7	22.0	20.7		
	650	26.7	26.2	25.5	25		
	1000	26.9	26.5	26.0	25.6		
	1500	27.1	26.8	26.3	26.0		
H P	150	0.67	1.1	1.9	2.8	4.5	
	650	1.0	1.5	2.3	3.1	4.6	
B	1000	1.2	1.7	2.5	3.3	4.7	
	1500	1.5	1.9	2.7	3.6	4.9	

Pump Rotor Size 143							
Speed 1425 RPM (50 Hz 4-pole)							
Viscosity SSU	Differential Pressure PSID						
	25	50	100	150			
G P M	33	11.6	10.0	N/A	N/A	P L S Z	* — — Z
	65	12.8	11.6	9.9	8.7		
	100	13.3	12.4	11.0	10.0		
	650	14.7	14.3	13.8	13.4		
	1000	14.9	14.6	14.2	13.8		
	1500	15.0	14.8	14.4	14.2		
H P	150	0.34	0.60	1.1	1.6	4.1	
	650	0.54	0.78	1.3	1.7	4.2	
B	1000	0.63	0.87	1.3	1.8	4.2	
	1500	0.74	0.98	1.5	1.9	4.3	

Pump Rotor Size 162							
Speed 1425 RPM (50 Hz 4-pole)							
Viscosity SSU	Differential Pressure PSID						
	25	50	100	150			
G P M	33	17.8	15.7	12.7	N/A	P L S Z	* — — Z
	65	19.2	17.7	15.6	14.0		
	100	19.9	18.7	17.0	15.7		
	650	21.7	21.2	20.6	20.0		
	1000	21.9	21.6	21.0	20.6		
	1500	22.1	21.8	21.4	21		
H P	150	0.52	0.86	1.6	2.2	4.2	
	650	0.78	1.1	1.8	2.5	4.3	
B	1000	0.91	1.3	1.9	2.6	4.4	
	1500	1.1	1.4	2.1	2.8	4.5	

 indicates exceeds current motor size availability N/A=not applicable
 * Net inlet pressure required is the minimum pressure above vapor pressure at pump inlet to prevent cavitation assuming liquid is air and gas free.

SERIES 3E

Pump Rotor Size 187							
Speed 3450 RPM (60 Hz 2-pole)							
Viscosity SSU	Differential Pressure PSID						
	25	50	100	150			
G P M	33	80.3	77.5	73.5	70.5	P L S I *	
	65	82.2	80.2	77.4	75.2		
	100	83.2	81.6	79.6	77.5		
	650	85.5	84.9	84.0	83.8		
	1000	85.8	85.3	84.6	84.0		
B H P	1500	86.0	85.6	85.0	84.6	Z P	
	150	2.8	4.1	6.7	9.2		8.3
	650	5.1	6.4	8.9	11.5		10.0
	1000	6.2	7.5	10.1	12.6		11.2
B	1500	7.7	8.9	11.5	14.1	13.4	

Pump Rotor Size 200							
Speed 3450 RPM (60 Hz 2-pole)							
Viscosity SSU	Differential Pressure PSID						
	25	50	100	150			
G P M	33	98.1	94.9	90.4	87.0	P L S I *	
	65	100	98.0	94.8	92.4		
	100	101	99.6	97.0	95.0		
	650	104	103	102	101		
	1000	104	103	103	102		
B H P	1500	104	104	104	103	Z P	
	150	3.4	5.0	8.1	11.2		9.3
	650	6.2	7.7	10.8	13.9		11.6
	1000	7.6	9.1	12.3	15.4		13.3
B	1500	9.3	10.9	14.0	17.1	16.8	

Pump Rotor Size 187							
Speed 2850 RPM (50 Hz 2-pole)							
Viscosity SSU	Differential Pressure PSID						
	25	50	100	150			
G P M	33	65.0	62.2	58.3	55.2	P L S I *	
	65	67.0	65.0	62.2	60.0		
	100	67.9	66.3	64.0	62.3		
	650	70.2	69.6	68.7	68.0		
	1000	70.5	70.0	69.3	68.8		
B H P	1500	70.8	70.4	69.8	69.3	Z P	
	150	2.1	3.2	5.3	7.4		6.6
	650	3.7	4.7	6.8	9.0		7.4
	1000	4.5	5.5	7.6	9.8		7.9
B	1500	5.4	6.5	8.6	10.7	8.7	

Pump Rotor Size 200							
Speed 2850 RPM (50 Hz 2-pole)							
Viscosity SSU	Differential Pressure PSID						
	25	50	100	150			
G P M	33	79.6	76.4	71.9	68.4	P L S I *	
	65	81.8	79.5	76.3	73.8		
	100	82.8	81.0	78.4	76.4		
	650	85.5	84.8	83.8	83.0		
	1000	85.9	85.3	84.5	83.8		
B H P	1500	86.1	85.6	85.0	84.5	Z P	
	150	2.6	3.8	6.4	9.0		7.1
	650	4.5	5.7	8.3	10.9		8.1
	1000	5.4	6.7	9.3	11.8		8.7
B	1500	6.6	7.9	10.4	13.0	9.8	

Pump Rotor Size 187							
Speed 1725 RPM (60 Hz 4-pole)							
Viscosity SSU	Differential Pressure PSID						
	25	50	100	150			
G P M	33	36.4	33.6	29.6	26.6	P L S I *	
	65	38.3	36.3	33.5	31.4		
	100	39.3	37.7	35.4	33.6		
	650	41.6	41.0	40.1	39.4		
	1000	41.9	41.4	40.7	40.1		
B H P	1500	42.1	41.7	41.1	40.7	Z P	
	150	1.0	1.7	3.0	4.2		4.7
	650	1.6	2.2	3.5	4.8		5.0
	1000	1.9	2.5	3.8	5.1		5.1
B	1500	2.3	2.9	4.2	5.5	5.3	

Pump Rotor Size 200							
Speed 1725 RPM (60 Hz 4-pole)							
Viscosity SSU	Differential Pressure PSID						
	25	50	100	150			
G P M	33	44.8	41.7	37.2	33.7	P L S I *	
	65	47.0	44.8	41.6	39.1		
	100	48.1	46.3	43.7	41.7		
	650	50.8	50.1	49.1	48.2		
	1000	51.1	50.5	49.7	49.1		
B H P	1500	51.4	50.9	50.2	49.7	Z P	
	150	1.3	2.0	3.6	5.1		4.9
	650	2.0	2.7	4.3	5.8		5.1
	1000	2.3	3.1	4.6	6.2		5.3
B	1500	2.8	3.5	5.1	6.6	5.3	

Pump Rotor Size 187							
Speed 1425 RPM (50 Hz 4-pole)							
Viscosity SSU	Differential Pressure PSID						
	25	50	100	150			
G P M	33	28.8	26.0	22.0	19.0	P L S I *	
	65	30.7	28.1	25.9	23.7		
	100	31.6	30.0	27.8	26.0		
	650	34.0	33.4	32.5	31.8		
	1000	34.3	33.8	33.1	32.5		
B H P	1500	34.5	34.1	33.5	33.1	Z P	
	150	0.80	1.3	2.4	3.4		4.4
	650	1.2	1.7	2.8	3.8		4.6
	1000	1.4	1.9	3.0	4.0		4.6
B	1500	1.6	2.2	3.2	4.3	4.8	

Pump Rotor Size 200							
Speed 1425 RPM (50 Hz 4-pole)							
Viscosity SSU	Differential Pressure PSID						
	25	50	100	150			
G P M	33	35.6	32.4	27.9	22.0	P L S I *	
	65	37.8	35.5	32.3	29.8		
	100	38.8	37.0	34.4	32.4		
	650	41.5	40.8	39.8	39.0		
	1000	41.9	41.3	40.5	39.8		
B H P	1500	42.1	41.6	41.0	40.5	Z P	
	150	0.97	1.6	2.9	4.2		4.5
	650	1.5	2.1	3.4	4.7		4.7
	1000	1.7	2.3	3.6	4.9		4.8
B	1500	2.0	2.6	3.9	5.2	4.9	

indicates exceeds current motor size availability N/A=not applicable
 * Net inlet pressure required is the minimum pressure above vapor pressure at pump inlet to prevent cavitation assuming liquid is air and gas free.

MODEL 3E CAST IRON CANNED MOTOR PUMPS

ALL DIMENSIONS IN INCHES
STANDARD ROTATION - CLOCKWISE

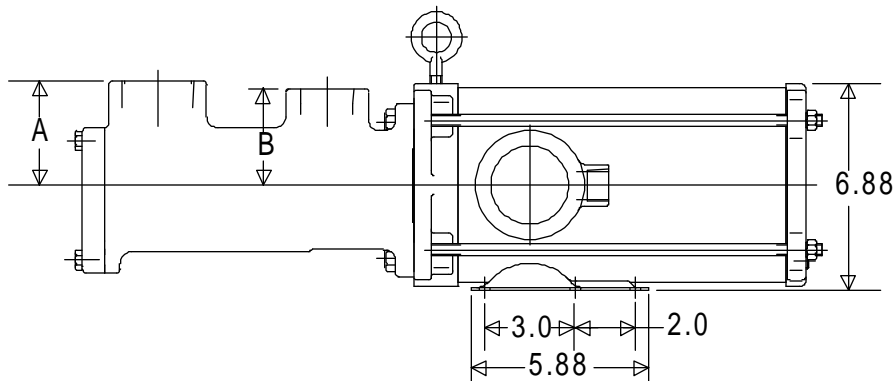
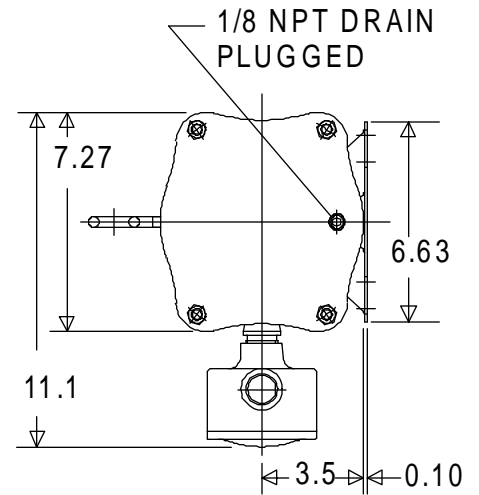
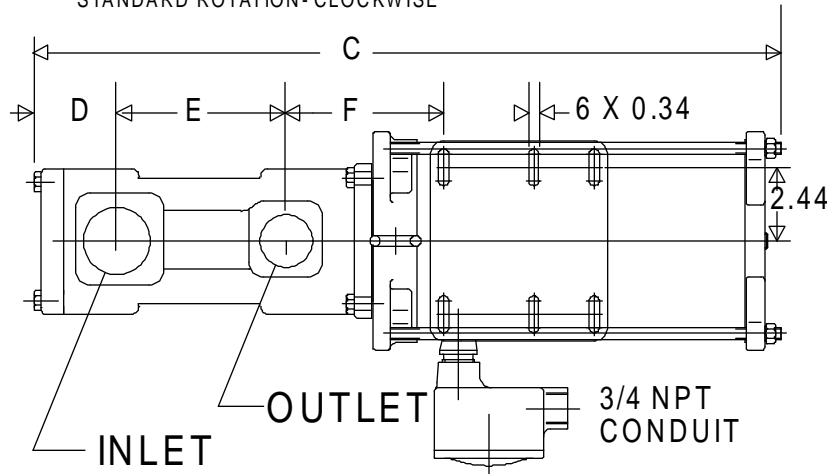

CERTIFIED BY	DATE
CUSTOMER	
CUSTOMER ORDER NUMBER	
TYPE	
IMO ORDER NUMBER	
MOTOR, POWER SUPPLY	

MODEL NUMBER	INLET#	OUTLET#	A	B	C	D	E	F	WEIGHT-LBS.
W0*003E087SPCV	1	1	2.63	2.63	19.94	1.56	2.13	4.86	9 + MOTOR**
W0*003E087SCCV	1	1	2.63	2.63	19.94	1.56	2.13	4.86	9 + MOTOR**
W0*003E095SCCV	1	1	2.63	2.63	19.94	1.56	2.13	4.86	9 + MOTOR**
W0*003E118SPCV	1-1/2	1	3.26	3.26	22.04	1.86	3.88	4.85	27 + MOTOR**
W0*003E118SCCV	1-1/2	1	3.26	3.26	22.04	1.86	3.88	4.85	27 + MOTOR**
W0*003E143JCV	2	1-1/2	3.63	3.38	24.81	2.74	5.63	5.22	38 + MOTOR**
W0*003E143SCCV	2	1-1/2	3.63	3.38	24.81	2.74	5.63	5.22	38 + MOTOR**
W0*003E162SCCV	2	1-1/2	3.63	3.38	24.81	2.74	5.63	5.22	38 + MOTOR**
W0*003E187SCCV	2-1/2	2	4.5	4.5	28.69	3.75	5.81	7.66	92 + MOTOR**
W0*003E200SCCV	2-1/2	2	4.5	4.5	28.69	3.75	5.81	7.66	92 + MOTOR**

* DIMENSIONS APPLY TO MOTOR SIZES 02, 03, 05, AND 06.

** MOTOR WEIGHTS: 02 = 68 LBS.; 03 = 71 LBS.; 05 = 74 LBS.; 06 = 77 LBS.

INLET AND OUTLET ARE NPT THREADED.

PUMP MAY BE ROTATED IN 90 DEGREE INCREMENTS RELATIVE TO THE PLANE OF THE MOTOR FOOT.

INLET HEAD ON SIZES 187 & 200 MAY BE ROTATED IN 90 DEGREE INCREMENTS RELATIVE TO THE PUMP OUTLET.

IMO PUMP, MONROE, NC 28111-5020, USA

SERIES 110H

Pump Rotor Size 87-1.6D						
Speed 3450 RPM (60 Hz 2-pole)						
Viscosity SSU	Differential Pressure PSID					N I P R * P S I
	250	300	500	750	1000	
G P M	33	N/A	N/A	N/A	N/A	N/A
	65	N/A	N/A	N/A	N/A	N/A
	100	4.1	3.9	N/A	N/A	N/A
	650	5.0	5.0	3.8	N/A	N/A
	1000	5.1	5.1	3.9	3.8	3.7
	1500	5.2	5.2	4.1	3.9	3.8
B H P	150	1.4	1.6	N/A	N/A	N/A
	650	1.9	2.2	3.0	N/A	N/A
	1000	2.2	2.4	3.3	4.3	5.3
	1500	2.6	2.8	3.6	4.6	5.7

Pump Rotor Size 87-2D						
Speed 3450 RPM (60 Hz 2-pole)						
Viscosity SSU	Differential Pressure PSID					N I P R * P S I
	250	300	500	750	1000	
G P M	33	N/A	N/A	N/A	N/A	N/A
	65	N/A	N/A	N/A	N/A	N/A
	100	5.5	5.4	N/A	N/A	N/A
	650	6.7	6.6	5.4	5.1	4.9
	1000	6.8	6.8	5.6	5.4	5.2
	1500	6.9	6.9	5.7	5.6	5.4
B H P	150	1.6	1.9	N/A	N/A	N/A
	650	2.1	2.3	3.4	4.7	6.0
	1000	2.3	2.6	3.6	4.9	6.2
	1500	2.6	2.9	3.9	5.2	6.5

Pump Rotor Size 87-1.6D						
Speed 2850 RPM (50 Hz 2-pole)						
Viscosity SSU	Differential Pressure PSID					N I P R * P S I
	250	300	500	750	1000	
G P M	33	N/A	N/A	N/A	N/A	N/A
	65	N/A	N/A	N/A	N/A	N/A
	100	N/A	N/A	N/A	N/A	N/A
	650	3.8	3.7	N/A	N/A	N/A
	1000	3.9	3.9	N/A	N/A	N/A
	1500	4.0	4.0	N/A	N/A	N/A
B H P	150	N/A	N/A	N/A	N/A	N/A
	650	1.5	1.7	N/A	N/A	N/A
	1000	1.7	1.8	N/A	N/A	N/A
	1500	1.9	2.1	N/A	N/A	N/A

Pump Rotor Size 87-2D						
Speed 2850 RPM (50 Hz 2-pole)						
Viscosity SSU	Differential Pressure PSID					N I P R * P S I
	250	300	500	750	1000	
G P M	33	N/A	N/A	N/A	N/A	N/A
	65	N/A	N/A	N/A	N/A	N/A
	100	4.0	3.8	N/A	N/A	N/A
	650	5.1	5.1	3.8	N/A	N/A
	1000	5.3	5.2	4.0	3.8	3.7
	1500	5.4	5.3	4.2	4.0	3.9
B H P	150	1.3	1.5	N/A	N/A	N/A
	650	1.6	1.8	2.7	N/A	N/A
	1000	1.8	2.0	2.8	3.9	5.0
	1500	2	2.2	3	4.1	5.2

Pump Rotor Size						
Speed 1725 RPM (60 Hz 4-pole)						
Viscosity SSU	Differential Pressure PSID					N I P R * P S I
	250	300	500	750	1000	
G P M	33					
	65					
	100					
	650					
	1000					
	1500					
B H P	150					
	650					
	1000					
	1500					

Pump Rotor Size						
Speed 1725 RPM (60 Hz 4-pole)						
Viscosity SSU	Differential Pressure PSID					N I P R * P S I
	250	300	500	750	1000	
G P M	33					
	65					
	100					
	650					
	1000					
	1500					
B H P	150					
	650					
	1000					
	1500					

Pump Rotor Size						
Speed 1425 RPM (50 Hz 4-pole)						
Viscosity SSU	Differential Pressure PSID					N I P R * P S I
	250	300	500	750	1000	
G P M	33					
	65					
	100					
	650					
	1000					
	1500					
B H P	150					
	650					
	1000					
	1500					

Pump Rotor Size						
Speed 1425 RPM (50 Hz 4-pole)						
Viscosity SSU	Differential Pressure PSID					N I P R * P S I
	250	300	500	750	1000	
G P M	33					
	65					
	100					
	650					
	1000					
	1500					
B H P	150					
	650					
	1000					
	1500					

■ indicates exceeds current motor size availability

N/A=not applicable

* Net inlet pressure required is the minimum pressure above vapor pressure at pump inlet to prevent cavitation assuming liquid is air and gas free.

SERIES 210H

Pump Rotor Size 95-2D								
Speed 3450 RPM (60 Hz 2-pole)								
Viscosity SSU	Differential Pressure PSID					Z P S I *	P S I *	
	250	300	500	750	1000			
G P M	33	N/A	N/A	N/A	N/A	N/A	Z P S I *	P S I *
	65	6.7	6.4	N/A	N/A	N/A		
	100	7.3	7.1	N/A	N/A	N/A		
	650	8.9	8.8	7.5	7.2	6.9		
	1000	9.1	9.0	7.8	7.5	7.3		
	1500	9.2	9.2	8.0	7.8	7.6		
H P	150	2.0	2.3	N/A	N/A	N/A	4.8	
	650	2.5	2.8	4.2	5.8	7.5	5.0	
B	1000	2.7	3.1	4.4	6.1	7.7	5.1	
	1500	3.0	3.4	4.7	6.4	8.0	5.3	

Pump Rotor Size 106-2D								
Speed 3450 RPM (60 Hz 2-pole)								
Viscosity SSU	Differential Pressure PSID					Z P S I *	P S I *	
	250	300	500	750	1000			
G P M	33	8.9	N/A	N/A	N/A	N/A	Z P S I *	P S I *
	65	10.5	10.1	N/A	N/A	N/A		
	100	11.3	10.9	8.9	7.9	N/A		
	650	13.2	13.1	11.7	11.3	10.9		
	1000	13.5	13.4	12.0	11.7	11.4		
	1500	13.6	13.6	12.3	12.0	11.8		
H P	150	2.8	3.3	5.1	7.4	N/A	5.0	
	650	3.5	4.0	5.8	8.1	10.5	5.3	
B	1000	3.8	4.3	6.2	8.5	10.8	5.5	
	1500	4.3	4.7	6.6	8.9	11.3	5.7	

Pump Rotor Size 95-2D								
Speed 2850 RPM (50 Hz 2-pole)								
Viscosity SSU	Differential Pressure PSID					Z P S I *	P S I *	
	250	300	500	750	1000			
G P M	33	N/A	N/A	N/A	N/A	N/A	Z P S I *	P S I *
	65	N/A	N/A	N/A	N/A	N/A		
	100	5.4	5.1	N/A	N/A	N/A		
	650	6.9	6.8	5.5	5.1	4.9		
	1000	7.1	7.0	5.8	5.5	5.3		
	1500	7.3	7.2	6.0	5.8	5.6		
H P	150	1.6	1.9	N/A	N/A	N/A	4.4	
	650	1.9	2.2	3.3	4.7	6.1	4.6	
B	1000	2.1	2.4	3.5	4.9	6.2	4.7	
	1500	2.3	2.6	3.7	5.1	6.4	4.8	

Pump Rotor Size 106-2D								
Speed 2850 RPM (50 Hz 2-pole)								
Viscosity SSU	Differential Pressure PSID					Z P S I *	P S I *	
	250	300	500	750	1000			
G P M	33	6.1	N/A	N/A	N/A	N/A	Z P S I *	P S I *
	65	7.7	7.3	N/A	N/A	N/A		
	100	8.5	8.2	6.1	N/A	N/A		
	650	10.4	10.3	8.9	8.5	8.2		
	1000	10.7	10.6	9.3	8.9	8.7		
	1500	10.9	10.8	9.5	9.3	9.0		
H P	150	2.2	2.6	4.2	N/A	N/A	4.6	
	650	2.7	3.1	4.6	6.6	8.5	4.8	
B	1000	3.0	3.3	4.9	6.8	8.7	4.9	
	1500	3.3	3.6	5.2	7.1	9.0	5.1	

Pump Rotor Size 95-2D								
Speed 1725 RPM (60 Hz 4-pole)								
Viscosity SSU	Differential Pressure PSID					Z P S I *	P S I *	
	250	300	500	750	1000			
G P M	33	N/A	N/A	N/A	N/A	N/A	Z P S I *	P S I *
	65	N/A	N/A	N/A	N/A	N/A		
	100	N/A	N/A	N/A	N/A	N/A		
	650	3.2	3.1	N/A	N/A	N/A		
	1000	3.4	3.3	N/A	N/A	N/A		
	1500	3.5	3.5	N/A	N/A	N/A		
H P	150	N/A	N/A	N/A	N/A	N/A	N/A	
	650	1.0	1.2	N/A	N/A	N/A	4.0	
B	1000	1.1	1.3	N/A	N/A	N/A	4.0	
	1500	1.2	1.4	N/A	N/A	N/A	4.1	

Pump Rotor Size 106-2D								
Speed 1725 RPM (60 Hz 4-pole)								
Viscosity SSU	Differential Pressure PSID					Z P S I *	P S I *	
	250	300	500	750	1000			
G P M	33	N/A	N/A	N/A	N/A	N/A	Z P S I *	P S I *
	65	N/A	N/A	N/A	N/A	N/A		
	100	N/A	N/A	N/A	N/A	N/A		
	650	5.2	5.1	N/A	N/A	N/A		
	1000	5.4	5.4	4.0	N/A	N/A		
	1500	5.6	5.6	4.3	4.0	N/A		
H P	150	N/A	N/A	N/A	N/A	N/A	N/A	
	650	1.5	1.7	N/A	N/A	N/A	4.1	
B	1000	1.6	1.8	2.7	N/A	N/A	4.1	
	1500	1.7	1.9	2.8	4.0	N/A	4.2	

Pump Rotor Size								
Speed 1425 RPM (50 Hz 4-pole)								
Viscosity SSU	Differential Pressure PSID					Z P S I *	P S I *	
	250	300	500	750	1000			
G P M	33						Z P S I *	P S I *
	65							
	100							
	650							
	1000							
	1500							
H P	150							
	650							
B	1000							
	1500							

Pump Rotor Size								
Speed 1425 RPM (50 Hz 4-pole)								
Viscosity SSU	Differential Pressure PSID					Z P S I *	P S I *	
	250	300	500	750	1000			
G P M	33						Z P S I *	P S I *
	65							
	100							
	650							
	1000							
	1500							
H P	150							
	650							
B	1000							
	1500							

■ indicates exceeds current motor size availability

N/A=not applicable

* Net inlet pressure required is the minimum pressure above vapor pressure at pump inlet to prevent cavitation assuming liquid is air and gas free.

SERIES 210H

Pump Rotor Size 118-1.6D								
Speed 3450 RPM (60 Hz 2-pole)								
Viscosity	SSU	Differential Pressure PSID					Z	P
		250	300	500	750	1000		
M G P C	33	10.9	10.4	N/A	N/A	N/A	P L S I *	Z P L
	65	12.5	12.1	9.9	8.7	N/A		
	100	13.2	12.9	10.9	10.0	9.1		
	650	15.1	15.0	13.6	13.2	12.9		
	1000	15.4	15.3	14.0	13.6	13.4		
	1500	15.5	15.5	14.2	14.0	13.7		
P T B	150	3.4	3.9	6.0	8.6	11.2	Z P L	4.8
	650	4.5	5.1	7.1	9.7	12.3		5.0
	1000	5.1	5.6	7.7	10.3	12.9		5.1
	1500	5.8	6.4	8.4	11.0	13.6		5.3

Pump Rotor Size 118-2D								
Speed 3450 RPM (60 Hz 2-pole)								
Viscosity	SSU	Differential Pressure PSID					Z	P
		250	300	500	750	1000		
M G P C	33	13.8	13.1	N/A	N/A	N/A	P L S I *	Z P L
	65	15.8	15.3	12.8	11.2	N/A		
	100	16.8	16.4	14.1	12.8	11.8		
	650	19.2	19.1	17.6	17.1	16.6		
	1000	19.5	19.4	18.0	17.6	17.3		
	1500	19.8	19.7	18.3	18	17.7		
P T B	150	3.9	4.6	7.2	10.4	13.4	Z P L	5.3
	650	4.9	5.5	8.1	11.4	14.6		5.7
	1000	5.4	6.0	8.6	11.7	15.1		6.0
	1500	6.0	6.6	9.2	12.5	15.7		6.3

Pump Rotor Size 118-1.6D								
Speed 2850 RPM (50 Hz 2-pole)								
Viscosity	SSU	Differential Pressure PSID					Z	P
		250	300	500	750	1000		
M G P C	33	7.8	7.3	N/A	N/A	N/A	P L S I *	Z P L
	65	9.4	9.0	N/A	N/A	N/A		
	100	10.1	9.8	7.8	N/A	N/A		
	650	12.0	11.9	10.5	10.1	9.8		
	1000	12.2	12.2	10.8	10.5	10.3		
	1500	12.4	12.4	11.1	10.8	10.6		
P T B	150	2.7	3.1	4.8	N/A	N/A	Z P L	4.4
	650	3.5	4.0	5.6	7.8	9.9		4.6
	1000	3.9	4.3	6.0	8.2	10.3		4.7
	1500	4.4	4.8	6.5	8.7	10.8		4.8

Pump Rotor Size 118-2D								
Speed 2850 RPM (50 Hz 2-pole)								
Viscosity	SSU	Differential Pressure PSID					Z	P
		250	300	500	750	1000		
M G P C	33	9.9	N/A	N/A	N/A	N/A	P L S I *	Z P L
	65	11.9	11.5	N/A	N/A	N/A		
	100	12.9	12.5	10.2	N/A	N/A		
	650	15.4	15.2	13.7	13.2	12.8		
	1000	15.6	15.5	14.1	13.7	13.4		
	1500	15.9	15.8	14.5	14.1	13.8		
P T B	150	3.1	3.7	5.8	N/A	N/A	Z P L	4.8
	650	3.8	4.3	6.5	9.2	11.8		5.1
	1000	4.1	4.7	6.8	9.5	12.2		5.2
	1500	4.5	5.1	7.2	9.9	12.6		5.4

Pump Rotor Size 118-1.6D								
Speed 1725 RPM (60 Hz 4-pole)								
Viscosity	SSU	Differential Pressure PSID					Z	P
		250	300	500	750	1000		
M G P C	33	N/A	N/A	N/A	N/A	N/A	P L S I *	Z P L
	65	N/A	N/A	N/A	N/A	N/A		
	100	N/A	N/A	N/A	N/A	N/A		
	650	6.2	6.1	4.7	N/A	N/A		
	1000	6.4	6.3	5.0	4.7	4.5		
	1500	6.6	6.5	5.2	5.0	4.8		
P T B	150	N/A	N/A	N/A	N/A	N/A	Z P L	N/A
	650	1.8	2.0	3.1	N/A	N/A		4.0
	1000	1.9	2.2	3.2	4.5	5.8		4.0
	1500	2.1	2.4	3.4	4.7	6		4.1

Pump Rotor Size 118-2D								
Speed 1725 RPM (60 Hz 4-pole)								
Viscosity	SSU	Differential Pressure PSID					Z	P
		250	300	500	750	1000		
M G P C	33	N/A	N/A	N/A	N/A	N/A	P L S I *	Z P L
	65	N/A	N/A	N/A	N/A	N/A		
	100	5.6	N/A	N/A	N/A	N/A		
	650	8.1	7.9	6.4	5.9	5.5		
	1000	8.4	8.3	6.8	6.4	6.1		
	1500	8.6	8.5	7.2	6.8	6.6		
P T B	150	1.8	N/A	N/A	N/A	N/A	Z P L	4.1
	650	2.0	2.4	3.7	5.3	6.9		4.2
	1000	2.2	2.5	3.8	5.4	7.0		4.2
	1500	2.3	2.6	3.9	5.6	7.2		4.3

Pump Rotor Size								
Speed 1425 RPM (50 Hz 4-pole)								
Viscosity	SSU	Differential Pressure PSID					Z	P
		250	300	500	750	1000		
M G P C	33						P L S I *	Z P L
	65							
	100							
	650							
	1000							
	1500							
P T B	150						Z P L	
	650							
	1000							
	1500							

Pump Rotor Size								
Speed 1425 RPM (50 Hz 4-pole)								
Viscosity	SSU	Differential Pressure PSID					Z	P
		250	300	500	750	1000		
M G P C	33						P L S I *	Z P L
	65							
	100							
	650							
	1000							
	1500							
P T B	150						Z P L	
	650							
	1000							
	1500							

 indicates exceeds current motor size availability N/A=not applicable
 * Net inlet pressure required is the minimum pressure above vapor pressure at pump inlet to prevent cavitation assuming liquid is air and gas free.

MODEL 110H & 210H CANNED MOTOR PUMPS

ALL DIMENSIONS IN INCHES
STANDARD ROTATION- CLOCKWISE

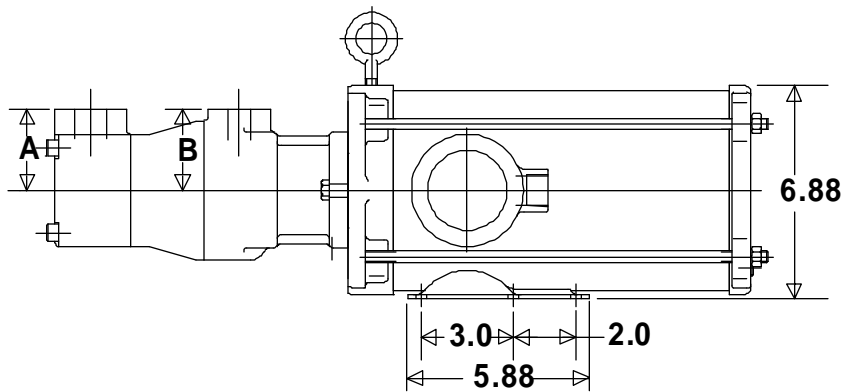
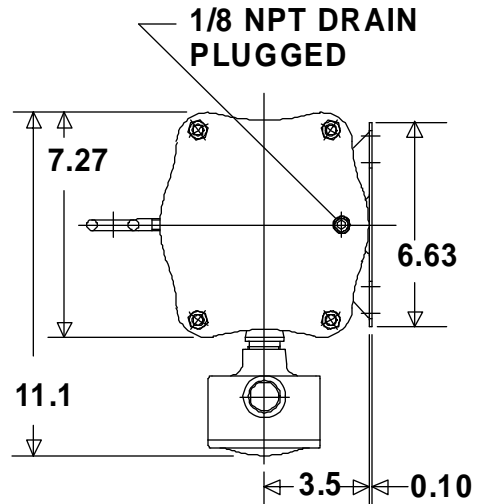
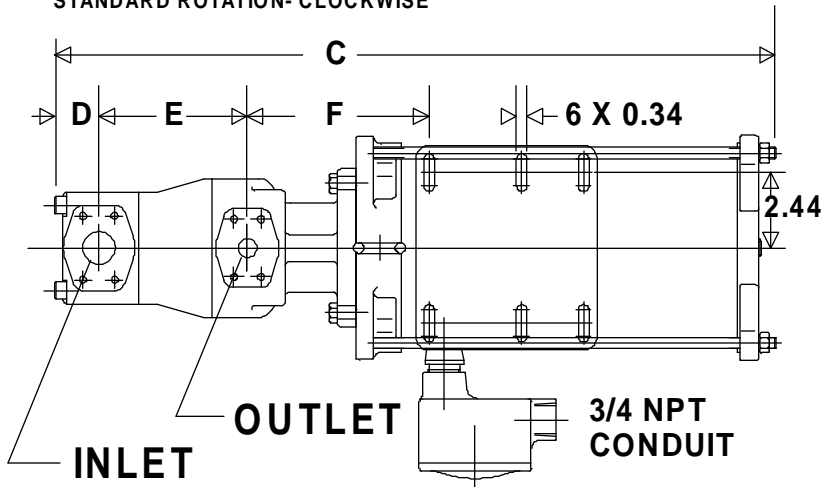

CERTIFIED BY	DATE
CUSTOMER	
CUSTOMER ORDER NUMBER	
TYPE	
IMO ORDER NUMBER	
MOTOR, POWER SUPPLY	

MODEL NUMBER	INLET#	OUTLET#	A	B	C	D	E	F	WEIGHT-LBS.
W0*110H087SPCV	3/4	1/2	2.5	2.5	19.99	2.25	4.88	5.31	18 + MOTOR**
W0*110H087SCCV	3/4	1/2	2.5	2.5	19.99	2.25	4.88	5.31	18 + MOTOR**
W0*210H095SCCV	1	3/4	2.63	2.63	23.3	1.41	4.81	5.87	30 + MOTOR**
W0*210H106SCCV	1	3/4	2.63	2.63	23.3	1.41	4.81	5.87	30 + MOTOR**
W0*210H118SPCV	1	3/4	2.63	2.63	23.3	1.41	4.81	5.87	30 + MOTOR**
W0*210H118SCCV	1	3/4	2.63	2.63	23.3	1.41	4.81	5.87	30 + MOTOR**

* DIMENSIONS APPLY TO MOTOR SIZES 02, 03, 05, AND 06.

** MOTOR WEIGHTS: 02 = 68 LBS.; 03 = 71 LBS.; 05 = 74 LBS.; 06 = 77 LBS.

INLET AND OUTLET ARE SAE 4-BOLT FLANGE PADS. MATING FLANGES MUST BE SPECIFIED/PURCHASED SEPARATELY.

PUMP MAY BE ROTATED IN 90 DEGREE INCREMENTS RELATIVE TO THE PLANE OF THE MOTOR FOOT.

INLET HEAD MAY BE ROTATED (WITH HOUSING) IN 90 DEGREE INCREMENTS RELATIVE TO THE PUMP OUTLET.

IMO PUMP, MONROE, NC 28111-5020, USA

Imo Pump Sales Offices

Calgary

Imo Pump
5918 5th Street, S.E.
Unit 14
Calgary, Alberta
Canada T2H 1L4
tel 403.253.7491
fax 403.252.9833

New Orleans

Imo Pump
2637 Edenborn Avenue
Suite 304
Metairie, LA 70002
tel 504.888.3333
fax 504.888.3337

Houston

Imo Pump
11811 N. Freeway
Suite 190
Houston, TX 77060
tel 281.448.1337
fax 281.445.2316

Toronto

Imo Pump
1401 Meyerside Drive
Unit A
Mississauga, Ontario
Canada L5T 1G8
tel 905.564.3344
fax 905.564.3577

Philadelphia

Imo Pump
515 Stump Road
Suite 222
North Wales, PA 19454
tel 215.393.7400
fax 215.393.7622

Caracas

Bombas Imo de Venezuela C.A.
Av. Rio Caura, Urb. Parque Humboldt
Centro Empresarial Torre Humboldt
Piso 5, Oficina 05-03, Prados del Este
Caracas, Venezuela
tel 975.4605, 4610
fax 975.4917

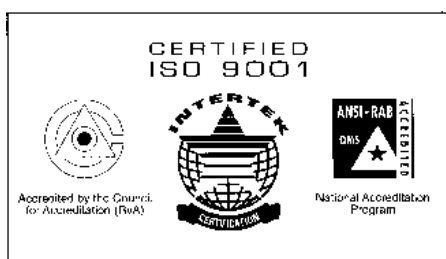

Quality Management System



The reliable pump people

Imo Pump

1710 Airport Road
PO Box 5020
Monroe, NC USA
28111.5020

tel 704.289.6511
fax 704.289.9273
email IMOPUMP@VNET.NET
web WWW.IMO-PUMP.COM