

REVISION HISTORY					
CHG NO	ZONE	REV	DESCRIPTION	DATE	BY / APPROVED
00-0579	ALL	1	UPDATED TO CURRENT STANDARDS	12-19-00	DMM / DMM

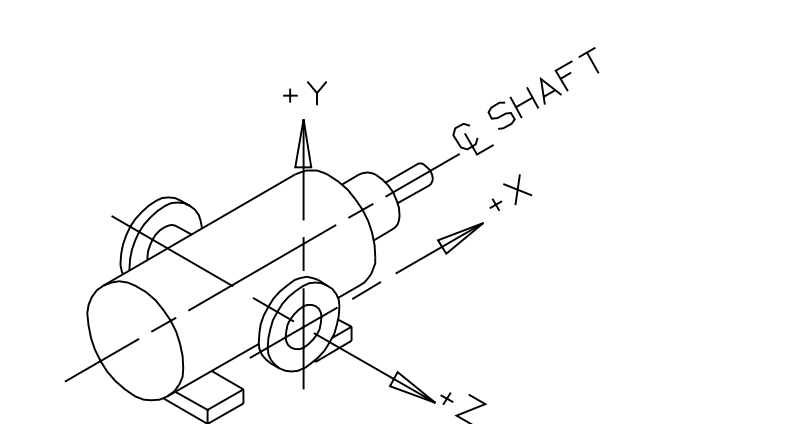
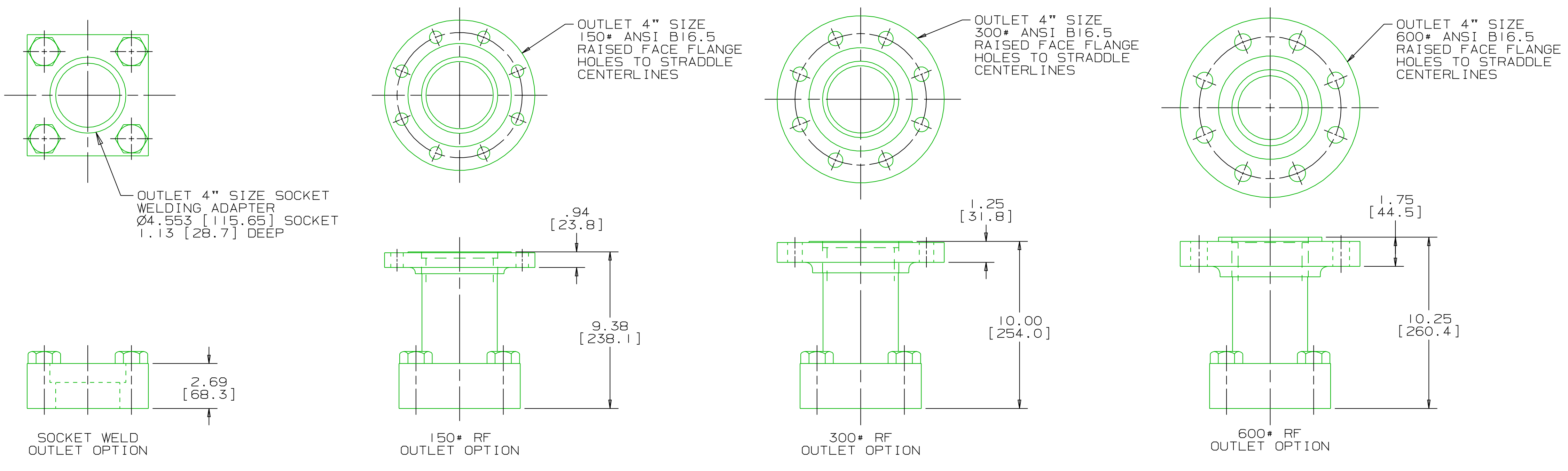

INLET:
 FX=375 LBF [1670 N] MX= 625 LB FT [847 N·m]
 FY=375 LBF [1670 N] MY= 625 LB FT [847 N·m]
 FZ=375 LBF [1670 N] MZ= 625 LB FT [847 N·m]

OUTLET:
 FX=300 LBF [1330 N] MX= 500 LB FT [678 N·m]
 FY=300 LBF [1330 N] MY= 500 LB FT [678 N·m]
 FZ=300 LBF [1330 N] MZ= 500 LB FT [678 N·m]

FORCE AND MOMENT VALUES ARE RELATIVE TO CENTER OF INLET AND OUTLET PORT FACES.

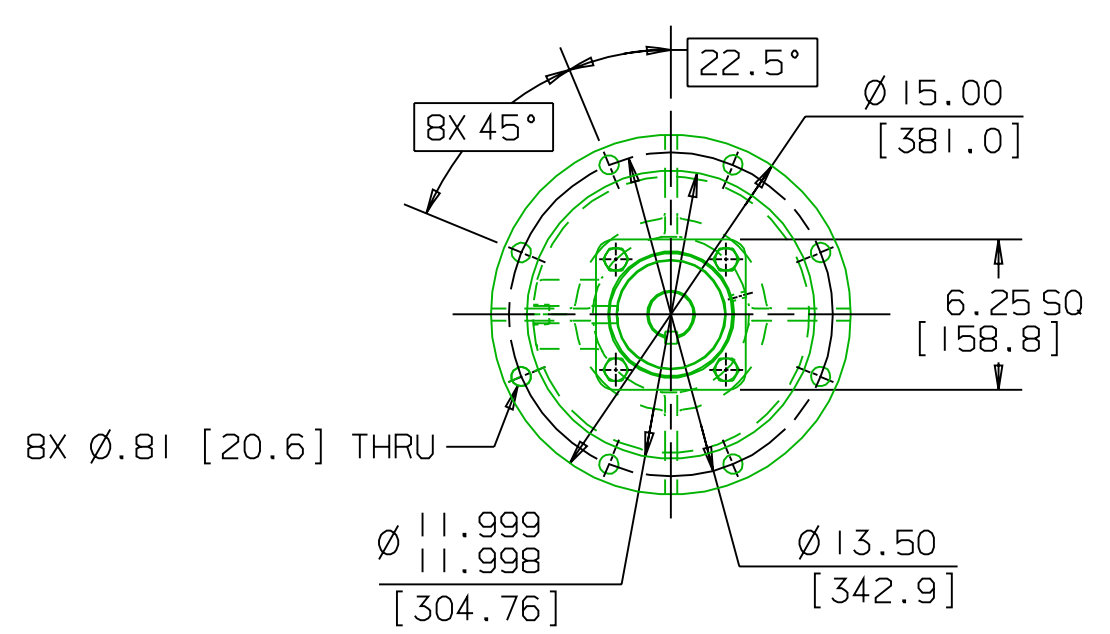
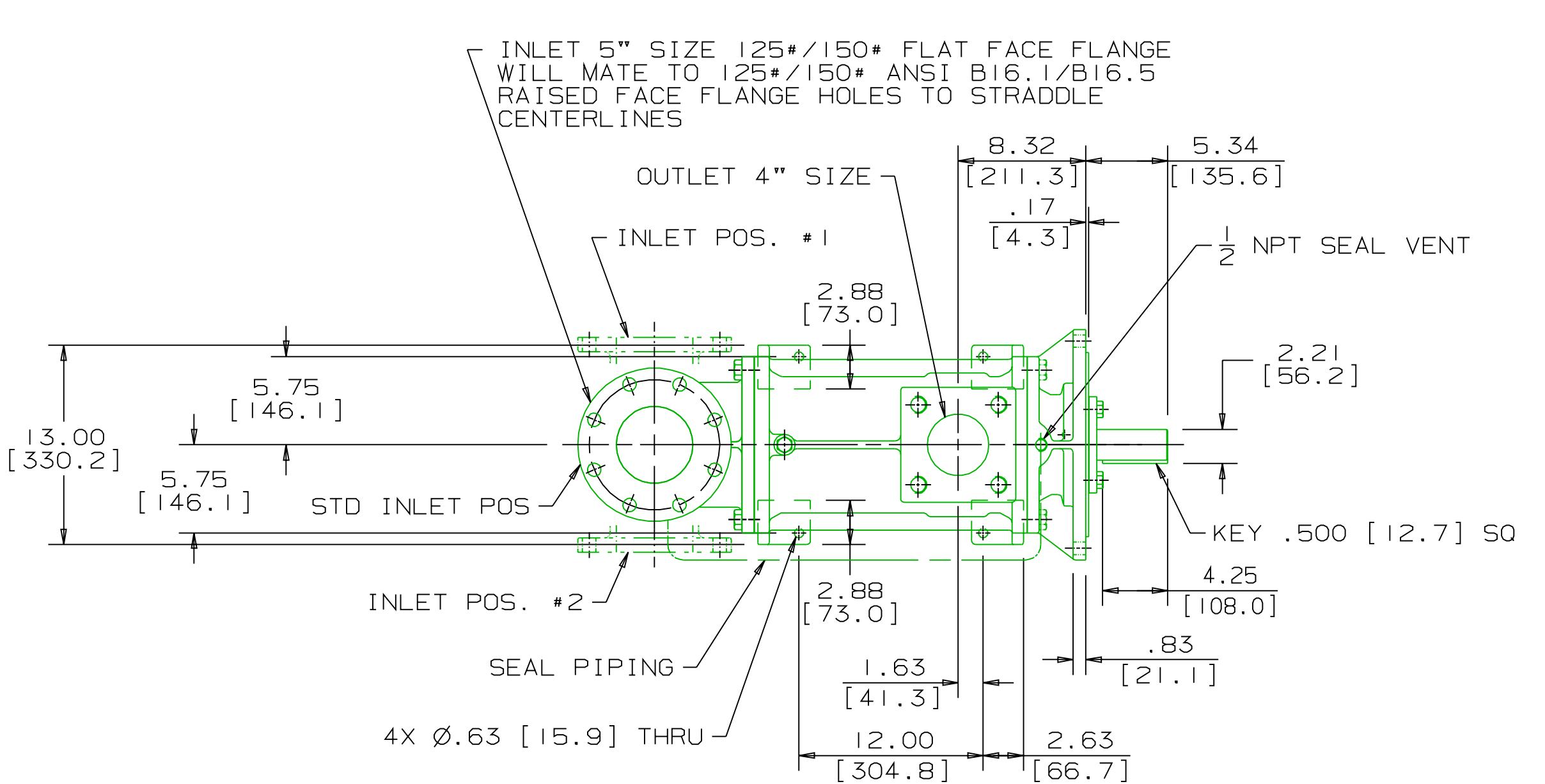

- NOTES:
- UNLESS OTHERWISE SPECIFIED, ALL DIMENSIONS ARE IN INCHES. DIMENSIONS IN [] ARE MILLIMETERS.
 - TO MAXIMIZE SEAL LIFE, SEAL VENT MUST BE ORIENTED UPWARD (12 O'CLOCK) WHEN PUMP IS INSTALLED HORIZONTALLY. THIS IS NORMAL VENT ORIENTATION WHEN PUMP FEET ARE ORIENTED DOWNWARD. SEAL VENT ORIENTATION IS NOT CRITICAL WHEN PUMP IS INSTALLED WITH SHAFT VERTICALLY UPWARD.
 - PORT, FOOT, AND SEAL VENT ORIENTATIONS ARE SUPPLIED AS SHOWN ON DRAWING UNLESS OTHERWISE SPECIFIED.
 - ALTERNATE INLET PORT POSITIONS ARE PROVIDED IF SPECIFIED ON ORDER. AVAILABLE POSITIONS ARE: STANDARD, POSITION #1, POSITION #2 OR POSITION #3. ALL INLET PORT POSITIONS ARE RELATIVE TO OUTLET PORT.
 - ESTIMATED WEIGHT (WITHOUT PORT ADAPTERS) 520 LBS [235.9 kg].

DRAWING CERTIFICATION	
CUSTOMER NAME	-----
CUSTOMER PO NUMBER	-----
CUSTOMER PART NUMBER	-----
BOM NUMBER	-----
PUMP TYPE	-----
SHAFT ROTATION	-----
INLET PORT POSITION	-----
OUTLET PORT ADAPTER OPTION	-----
OTHER INFORMATION	
CERTIFIED BY	-----
CERTIFIED DATE	-----
IMO ORDER NUMBER	-----
DATA REVISION NUMBER	-----

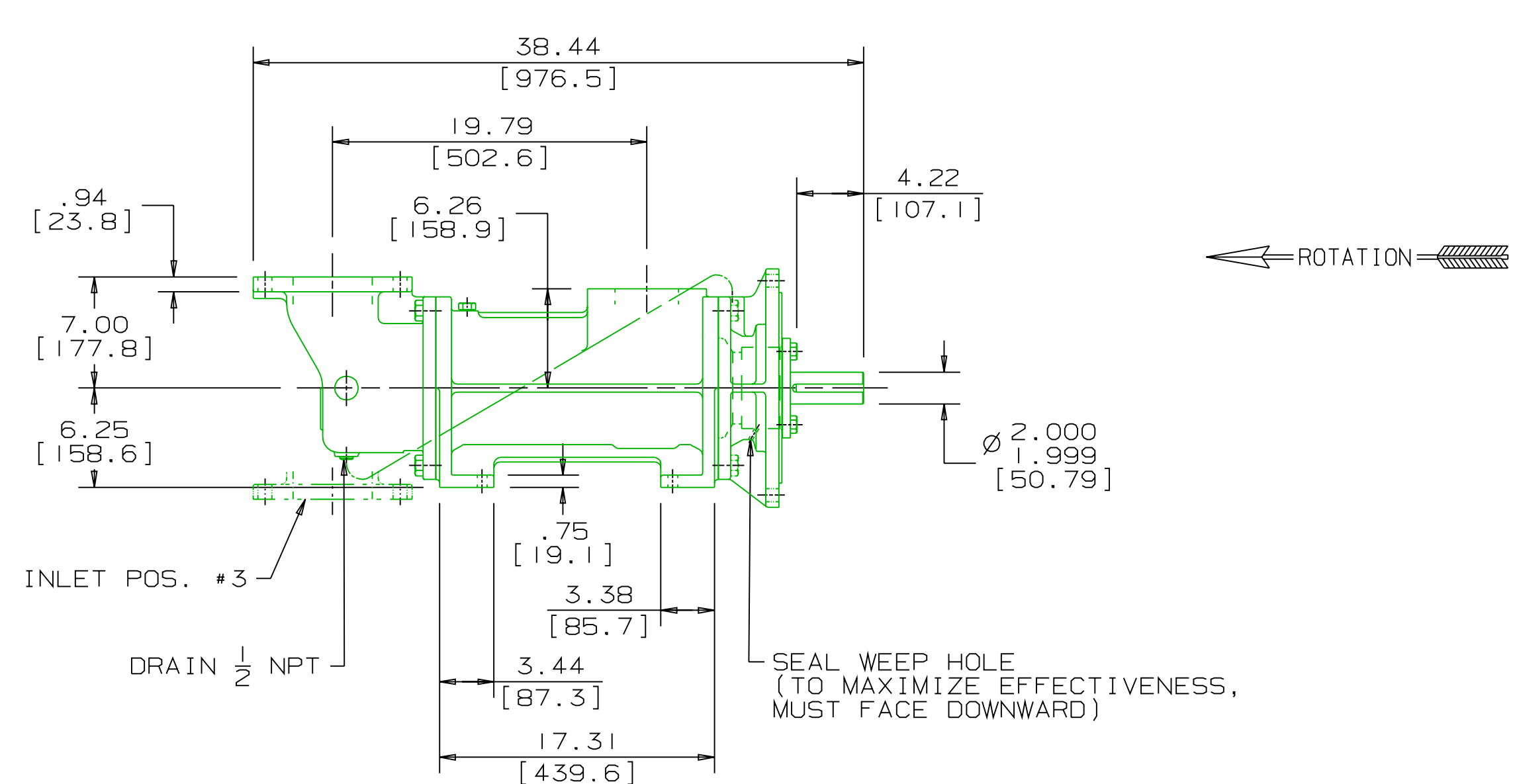

FACE MOUNT, RIGHT ANGLE INLET
STEEL 3D-337/350

WEB ADDRESS: WWW.IMO-PUMP.COM EMAIL: IMO.PUMP@COLFAXCORP.COM

DRAWN JTT 08-08-97
 CHECKED MJC 8-11-97
 APPD MJC 8-11-97

Imo Pump
 1710 Airport Road
 PO Box 5020
 Monroe, NC USA
 28111.5020

TITLE
 OUTLINE STANDARD (STEEL)
 3D-CS-337/350

THIRD ANGLE PROJECTION FIRST ORDER SIZE CAGE CODE DWG NO
 813745 D 59180 SDD19115

3222/033 SCALE 1/8 WEIGHT SEE NOTE 5 SHEET 1 OF 1