



**INSTRUCTION MANUAL
AND
PARTS LIST
FOR
K12DHz AND AK12DHz PUMPS**



WARNING

This manual, and GENERAL INSTRUCTIONS MANUAL, CA-1, should be read thoroughly prior to pump installation, operation or maintenance.

Manual No. SRM00041

Rev 02 (07-0026)

January 2007



READ ENTIRE PAGE BEFORE PROCEEDING

FOR THE SAFETY OF PERSONNEL AND TO PREVENT DAMAGE TO EQUIPMENT, THE FOLLOWING NOMENCLATURE HAS BEEN USED IN THIS MANUAL:

	DANGER	Failure to observe the precautions noted in this box can result in severe bodily injury or loss of life.
---	---------------	--

	WARNING	Failure to observe the precautions noted in this box can cause injury to personnel by accidental contact with the equipment or liquids. Protection should be provided by the user to prevent accidental contact.
---	----------------	--

	CAUTION		ATTENTION	
Failure to observe the precautions noted in this box can cause damage or failure of the equipment.				

Non compliance of safety instructions identified by the following symbol could affect safety for persons: 	Safety instructions where electrical safety is involved are identified by: 	Safety instructions which shall be considered for reasons of safe operation of the pump and/or protection of the pump itself are marked by the sign: <p style="text-align: center;">ATTENTION</p>
--	---	---

CONTENTS

SAFETY AND TABLE OF CONTENTS	A
A. GENERAL INSTRUCTIONS	1
B. INTRODUCTION	1
C. DESCRIPTION OF THE PUMP	1
D. PUMP MODEL IDENTIFICATION	2
E. ORDERING INSTRUCTIONS	2
F. OPERATION	2
G. PARTS LIST	3
H. PUMP MAINTENANCE	4
I. TROUBLESHOOTING	7
J. FIELD AND FACTORY SERVICE AND PARTS	7
K. ASSEMBLY DRAWING	8

	ATTENTION	<p><i>If operation of pump is critical to your business, we strongly recommend you keep a spare pump or major repair kit in stock at all times. As a minimum, a minor repair kit (o-rings, gaskets, shaft seal and bearings) should be kept in stock so pump refurbishment after internal inspection can be accomplished.</i></p>
--	------------------	---

A. GENERAL INSTRUCTIONS

The instructions found herein cover the disassembly, assembly and parts identification of Series AK and K12DHZ pumps.

NOTE: Individual contracts may have specific provisions that vary from this manual. Should any questions arise which may not be answered by these instructions, refer to General Instructions Manual, CA-1, provided with your order. For further detailed information and technical assistance please refer to Imo Pump, Technical/Customer Service Department, at (704) 289-6511.

This manual cannot possibly cover every situation connected with the installation, operation, inspection, and maintenance of equipment supplied. Every effort was made to prepare the text of the manual so that engineering and design data is transformed into the most easily understood wording. Imo Pump must assume personnel assigned to operate and maintain supplied equipment and apply this instruction manual have sufficient technical knowledge and are experienced to apply sound safety and operational practices which may not be otherwise covered by this manual.

In applications where equipment furnished by Imo Pump is to become part of processing machinery, these instructions should be thoroughly reviewed to ensure proper fit of said equipment into overall plant operational procedures.



WARNING

If installation, operation and maintenance instructions are not correctly and strictly followed and observed, injury to personnel or serious damage to pump could result. Imo Pump cannot accept responsibility for unsatisfactory performance or damage resulting from failure to comply with instructions.

B. INTRODUCTION

This instruction manual covers Series AK and K12DHZ Imo pumps. This series of pumps has been designed for use in hydraulic, lubricating and seal applications requiring high inlet pressure capabilities. The model, and design construction of each pump can be identified by the designator code on the pump nameplate. Definitions of model designators are identified in Figure 1.

C. DESCRIPTION OF EQUIPMENT

The AK and K12D Series pumps are positive displacement, rotary screw pumps consisting of a precision bored housing that encloses a driven screw (power rotor) and eight intermeshing following screws (idler rotors). These screws, when rotating, form a succession of closures or cavities. As they rotate, fluid is moved axially from inlet port to outlet port in a continuous, uniform flow with minimum fluid pulsation and pump noise.

D. PUMP MODEL IDENTIFICATION

This instruction manual covers the Imo Series AK and K12DHZ pumps with rotor size 187, 218, 250, 275, 312 and 350. The model of each pump is identified on pump nameplate. Refer to Figure 1 and Table 2 for instructional keys when using this manual.

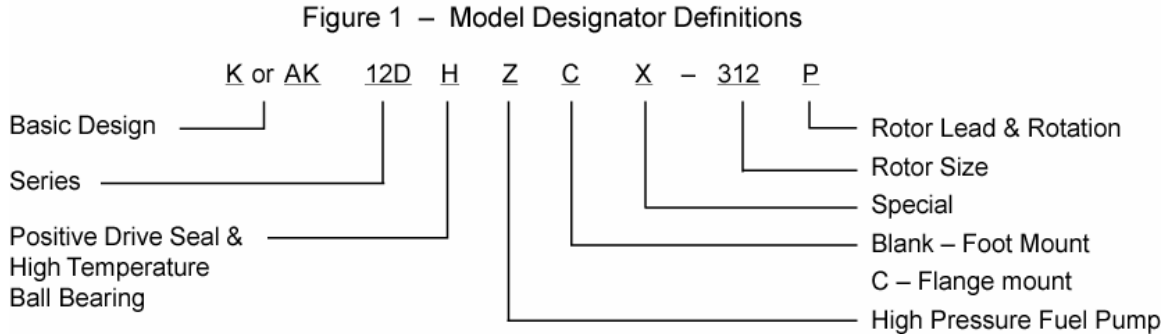

E. ORDERING INSTRUCTIONS

When corresponding with Imo Pump regarding Series AK or K12DHZ pumps, refer to pump nameplate, this instruction manual, and assembly drawing as instructed below:

1. From pump nameplate, record the pump model number, serial number and manufactured date.
2. Record instruction manual number, revision and date.
3. From the assembly drawing and/or parts list (table 2) in manual, provide IDP number(s) and names for replacement part(s).
4. Give above information to your Imo service representative.

Imo sales and service representatives are listed herein and in General Instruction Manual, CA-1.

F. OPERATION

F.1 LIQUID LIMITATIONS

Never operate with thin liquids such as solvents or water. The pump is designed for liquids having general characteristics of oil.

F.2 OPERATING LIMITS

CAUTION	ATTENTION
Operating conditions, such as speed, fluid viscosity, temperature inlet pressure, discharge pressure, filtration, duty cycle, drive type, mounting, etc., are interrelated. Due to these variable conditions, specific application limits may be different from that of operational limitations. Equipment must not be operated without verifying system's operating requirements are within pump's capabilities.	

Under no circumstances are the following operating limits (specified in Table 1) to be exceeded without specific approval from Imo Pump.

Table 1 – Normal Pump Operating and Structural Limits

MAXIMUM SPEED	3600 RPM
VISCOSITY	1 cSt Minimum – 3000 SSU (650 cSt) Maximum
MINIMUM – MAXIMUM LIQUID TEMPERATURE.....	0 to 250 F (-18 to 121 C)
MAXIMUM INLET PRESSURE.....	150 psig
MAXIMUM DISCHARGE PRESSURE	2200 psig, Cont. Duty
FILTRATION	(See General Instruction Manual, CA-1)
DRIVE	Direct only
MOUNTING	Foot or Flange mounted in any attitude

G. PARTS LIST

Table 2 – Pump Parts List

IDP	QTY	DESCRIPTION	KIT	IDP	QTY	DESCRIPTION	KIT
1	1	Case		41	2	Nilos Rings (AK design only)	
2	1	Inlet Head		42	2	Retaining Ring	X
3	2	Vent Pin	XX	43	1	Retainer	
4	8	Bolt (16 on sizes >= 275)		46	1	Inboard Cover	
5	4	Bolt (on 187 C-Face only)		47	4	Bolt	
6	1	Stop Pin	XX	48	1	Spacer	
7	1	Dyna Seal	X	49	1	Ball Bearing	X
8	2	Retaining Ring	XX	63	1	Power Rotor	XX
9	1	O-Ring	X	66	1	90° Elbow (Not on 250)	
10	1	Pin (Not on 275 or 312 sizes)		67	2	Plug	
21	2	Suction Idler	XX	68	1	Nipple (Not on 187 and 250)	
22	1	Idler Stop	XX	69	1	Fitting (Not on 187 and 250)	
23	2	Idler Balance Piston Housing		70	1	Elbow	
24	1	Discharge Housing	XX	71	1	Seal Pipe	
25	1	Seal	X	73	1	Suction Housing	XX
26	2	Tube (3 on 275 & 312 size)	XX	74	1	Elbow (250 Only)	
27	4	O-Ring	X	79	1	Bushing	XX
28	2	O-Ring	X	80	1	O-Ring	X
29	1	Cage	XX	81	1	Cap Screw	
31	1	Key	XX	91	1	Inboard Cover Washer (275 and 312 sizes only)	
35	6	Discharge Idlers	XX				
38	2	Seal Spacer (Not on 187 and 350 sizes)					

X = Minor Repair Kit Items.
 XX = Major Repair Kit Items. (Items marked (X) are included in Major Repair Kit).

H. PUMP MAINTENANCE



WARNING

Failure to observe precautions while installing, inspecting, and maintaining pump can cause injury to personnel from accidental handling of liquids that may harm skin or clothing, or fire hazard risks from flammable liquids, or injury from high pressure fluid jets.



DANGER

BEFORE working on equipment, make sure all power to equipment is disconnected and locked-out.

H.1 GENERAL COMMENTS

NOTE: Part number identifiers (IDPs) contained within parenthesis such as (10) refer to circled numbers shown on assembly drawing, figure 2 and Table 2.

H.2 TOOLS REQUIRED

Procedures described in this manual require common mechanics hand tools, a torque wrench, dial indicator and suitable lifting device (such as) slings, straps, etc.

H.3 DISASSEMBLY PROCEDURES

SPECIAL NOTE: To service mechanical seal and ball bearings **ONLY** perform H.3, Steps 1, 7, 8 and 9 and H.4, Steps 8, 9, 10, 11 and 12 **ONLY**.



CAUTION

Fluid leakage from disassembly of pump may make floor slippery and cause personal injury.

1. Close suction and discharge piping to pump and disconnect piping. Remove seal piping (71). Remove drain plugs (67), and drain unit. Remove pump from driver, coupling and base plate. Remove coupling hub and key (31).
2. Remove bolts (4) and inlet head (2). Remove O-ring (9) from inlet head (2).
3. Remove spiral rings (8) from grooves in case (1).
4. Remove thrust cage (29), then oil balance tube (26) with O-rings (27) from either cage (29) or inlet housing (73). Remove O-rings (27) from tube (26).
5. Remove idler balance piston housings (23) from suction idlers (21).
6. Remove suction idlers (21) by unscrewing them from inlet end of pump. Remove remaining idlers (35) from housings (73, 24) by rotating power rotor (63) in a counter-clockwise direction.

CAUTION

Do not permit idlers (21, 35) to drop as they emerge from housings (73, 24).

7. Remove bolts (47), bearing retainer (43) and Nilos ring ((41) (AK design only)) from inboard cover (46).

8. Remove assembled power rotor (63). Removal of power rotor (63) includes removal of Truarc rings (42), ball bearing (49), seal adapter (48), spacer (38), mechanical seal (25) and Nilos ring ((41) (AK design only)).
9. Disassemble power rotor (63) as follows:
 - a. Using a flat nosed tool, such as a screw driver, remove Truarc rings (42) located on both sides of ball bearing (49) from their grooves in power rotor (63).
 - b. Sealed ball bearing is assembled to power rotor (63) with a light press fit. Ball bearing (49) may be removed by using a bearing puller or a vertical arbor press. When using press, two pieces of key stock are to be placed through openings of mechanical seal seat adapter (48) underneath ball bearing (49) on both sides of power rotor shaft. Key stock should be long enough to support power rotor (63) as it is placed in press. Press ram is to be positioned against power rotor (63) coupling end face. Gently press power rotor (63) through ball bearing (49). Ensure power rotor (63) does not fall to floor once ball bearing (49) is off of its diameter.
 - c. Remove Nilos rings (41) from the power rotor(63)(AK design only).
 - d. Remove seal seat adapter (48) from power rotor (63), then remove mechanical seal stationary seat from seal seat adapter (48). Loosen set screws on mechanical seal rotating assembly body and remove from power rotor (63). Remove spacer (38) from the power rotor (63).
10. Remove O-ring (80) from inboard end cover (46).
11. Remove bolts (4) and inboard cover (46) from case (1).
12. Remove O-ring (28) from inboard cover (46).
13. Remove pin (10) from idler stop (22) or tube (26) if pump size 275 or 312.
14. Remove idler stop (22) from inboard cover (46) by removing bolts (81).
15. Remove floating balance piston (79) from inboard cover (46).
16. Remove stop pin (6) and Dyna seal (7) from case (1).
17. Remove housing (24) from case (1) and O-ring (28) from housing (24).

CAUTION

Do not permit housing (24) to drop as it is removed from pump.

18. Remove tube (26) from housing (24 or 73), and O-rings (27) from tube (26).
19. Remove aligning vent pins (3) from housing (24 or 73).
20. Remove housing (73) from case (1).

CAUTION

Do not permit housing (73) to drop as it is removed from pump.

H.4 PUMP ASSEMBLY PROCEDURE

Note: Prior to reassembly of pump, all parts should be cleaned and inspected for nicks and burrs. Replace all worn or damaged parts. Imo Pump recommends replacement of all O-rings (9, 27, 28, 80), Dyna Seal (7), mechanical seal (25) and ball bearing (49) when these parts are disturbed from their previously installed positions. Coat all parts with light lubricating oil to assist in assembly.

Note: Bolts (81) (except for 187 rotor size) have Nylok threads. Torque stated on assembly drawing for bolt (81) does not include additional torque to install fasteners containing nylok inserts. Torque required for first application is much higher than for subsequent applications. To ensure required preload on Nylok fastener is achieved for each application, the following procedure is mandatory assembly practice.

1. Using a suitable torque wrench, install fastener in mating piece until Nylok insert is completely engaged. Note torque required.
 2. Add torque measured in step 1. to torque value on assembly drawing.
 3. Complete tightening fastener to torque value determined in 2.
-
1. Install O-ring (28) in groove of discharge housing (24).
 2. Install discharge housing (24) in pump case (1), from suction end of case, aligning groove in housing (24) to stop pin hole in case (1). Install stop pin (6) with Dyna Seal (7) in case (1).
 3. Install O-rings (27) on oil balance tube (26) and oil balance tube (26) in one end of inlet housing (73). Install stop pins (3) in same end of inlet housing (73).
 4. Install assembled inlet housing (73) in case (1), ensuring that oil balance tube (26) and vent pins (3) engage holes in discharge housing (24).
 5. Install pin (10) or tube (26) if pump sizes 275 or 312, in outboard end of discharge housing (24)
 6. Install balance piston (79) on inboard cover (46). Install idler stop (22) on inboard cover (46) with cap screws (81). Torque cap screws to value on assembly drawing. Install O-rings (28 & 80) on inboard cover (46).
 7. Install inboard cover (46) on case (1) using bolts (4). Be sure that pin (10) or tube (26) (if pump sizes 275 or 312) lines up with pin hole in inboard cover (46). Torque bolts to proper value on assembly drawing.
 8. Assemble power rotor (63) and mechanical seal (25) as follows (see seal insert Figure 2).
 - a. Install O-ring (2) in groove of mechanical seal (25) stationary seat (1). Install mechanical stationary seat (1) in seal spacer (48) ensuring that spring pin is properly positioned to engage slot in seal seat.
 - b. Install spacer (38) on power rotor (63) when required.
 - c. Install mechanical seal (25) rotating assembly (3) on power rotor (63) next to spacer (38). Tighten set screws (3E).
 - d. Wipe mechanical seal rotating and stationary faces with a clean, lint free cloth before assembling faces together.
 - e. Install assembled bearing spacer (48), with stationary seat (1), to power rotor shaft next to mechanical seal rotating face.
 - f. Install one Nilos ring (41) onto power rotor (63) with sharp edge facing bearing (49) (on AK design only).

- g. Install inner Truarc ring (42) in groove of power rotor (63).
 - h. Press bearing (49) on power rotor (63), pressing only on inner race of ball bearing (49) until it is located next to inner Truarc ring (42).
 - i. Install outer Truarc ring (42) in groove of power rotor (63).
9. Install O-ring (80) in seal bore of inboard cover (46).
 10. Install assembled power rotor (63) in pump, centering all parts as they enter inboard cover (46). Align one of openings in spacer (48) over drain in inboard cover (46).
 11. Install 2nd Nilos ring (41) on inboard cover (46) with sharp edge facing bearing (49) being sure Nilos ring (41) is centered against bearing (on AK design only)
 12. Install bearing retainer (43) on inboard cover (46) using bolts (47). Torque bolts to values indicated on assembly drawing.
 13. Install idlers (35, 21) into housings by meshing threads with power rotor thread and screwing them into housing idler bores.
 14. Install idler balance piston housings (23) to ends of suction idlers (21).
 15. Install O-rings (27) on oil balance tube (26) and oil balance tube (26) in inlet housing (73).
 16. Install thrust cage (29) to pump case (1), ensuring that pin hole in thrust cage (29) engages tube (26) in suction housing (73).
 17. Install retaining rings (8) to pump case (1).
 18. Install O-ring (9) to groove in inlet head (2).
 19. Install inlet head (2) using bolts (4). Torque bolts to values indicated on assembly drawing.
 20. Install seal piping (71) and drain plug (67).

Note: Inlet head (2) can be rotated and repositioned in 90° increments to suit suction piping. To change inlet position, disconnect seal piping (71), remove bolts (4) and rotate inlet head to desired position. Install bolts (4) and torque to proper values indicated on assembly drawing. Reconnect seal piping (71).
 21. Install coupling hub key (31). Install and align pump and driver as specified in General Instruction Manual, CA-1.

H.5 SPECIAL TESTING INSTRUCTIONS

After pump has been reassembled with a major kit, it is recommended that a break-in test be performed to allow idlers to polish into babbitt housing bores. For this test, pump should be run to maximum required working pressure starting from 300 psig, in 200 psig increments, holding each pressure for five minutes.

I. TROUBLESHOOTING

For assistance with troubleshooting see General Instruction Manual, CA-1.

J. FIELD AND FACTORY SERVICE AND PARTS

Imo Pump maintains a staff of trained service personnel that can provide pump installation, pump start-up, maintenance/overhaul and troubleshooting supervision as well as installation and maintenance training.

Our factories provide maintenance as well as overhaul and test facilities in the event user prefers to return pumps for inspection or overhaul. Pumps that have been factory-overhauled are normally tested and warranted "as-new" for a period of one year from date of shipment. For either field service or factory overhaul assistance, contact your local Imo Sales Office or representative at Technical/Customer Service Department in Monroe, NC, USA.

Most pumps have repair kits available. Minor Repair Kits are used to repair leaking seals, bad bearings and/or for re-assembly after pump tear-down. They include (as applicable) pump shaft seals, packing, all gaskets/O-rings and bearings. Major Repair Kits are sufficient to rebuild completely worn-out pumps to "as-new" condition. They include all parts found in Minor Repair Kits plus all major internal parts subject to wear. Since kits have all necessary parts, it is preferred that they be purchased rather than selecting individual parts. When parts are individually selected from Parts List, some needed components are often overlooked. In addition, mixing worn or used parts with new parts risks rapid wear and shortened service life from new parts.

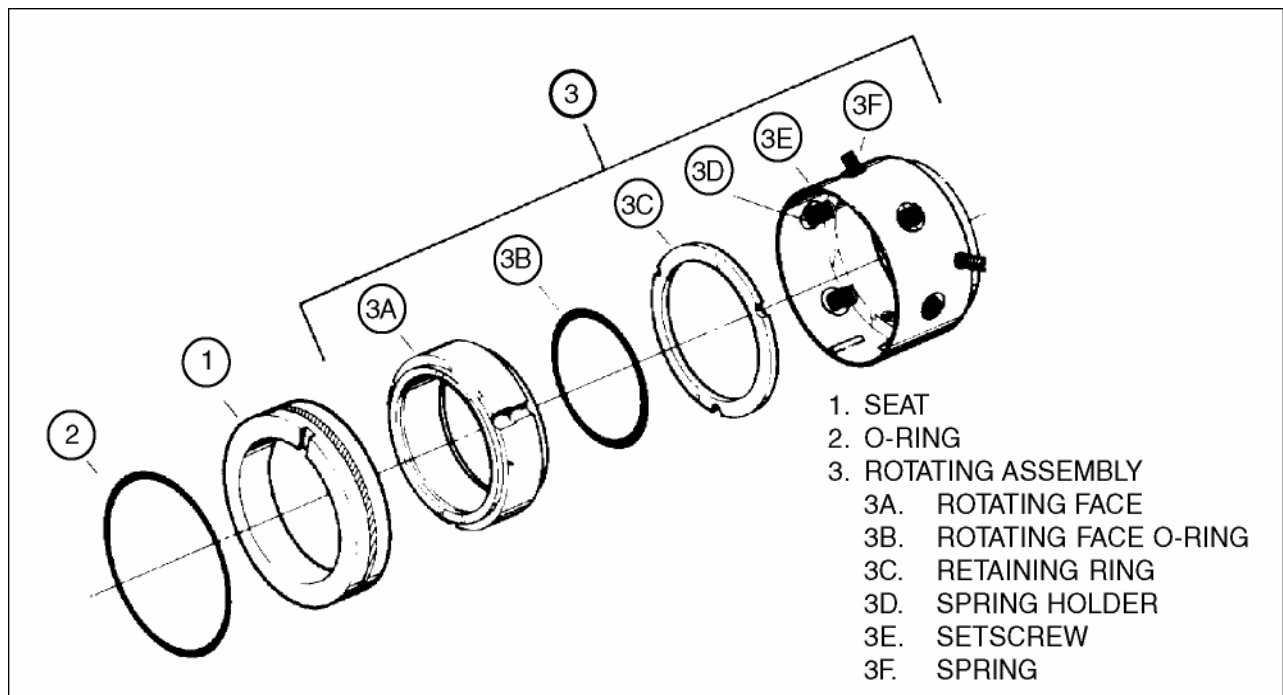
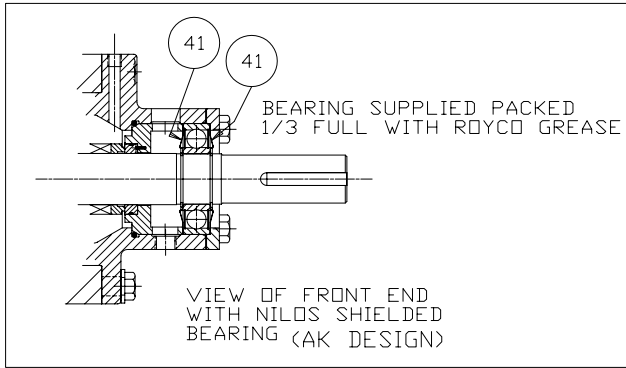

Figure 2 – Borg Warner Type Q Mechanical Seal or Crane Type 8-1 Mechanical Seal

Pump Size	Torque LB-FT
187	90 ± 5
218	100 ± 10
250	160 ± 10
275	60 ± 5
312	60 ± 5
350	100 ± 10



Pump Size	Torque
187	27 ± 2 LB-IN
218	65 ± 5 LB-IN
250	65 ± 5 LB-IN
275	18 ± 2 LB-FT
312	18 ± 2 LB-FT
350	65 ± 5 LB-IN

SLOT IN BEARING SPACER TO
LINE UP WITH HOLE IN COVER

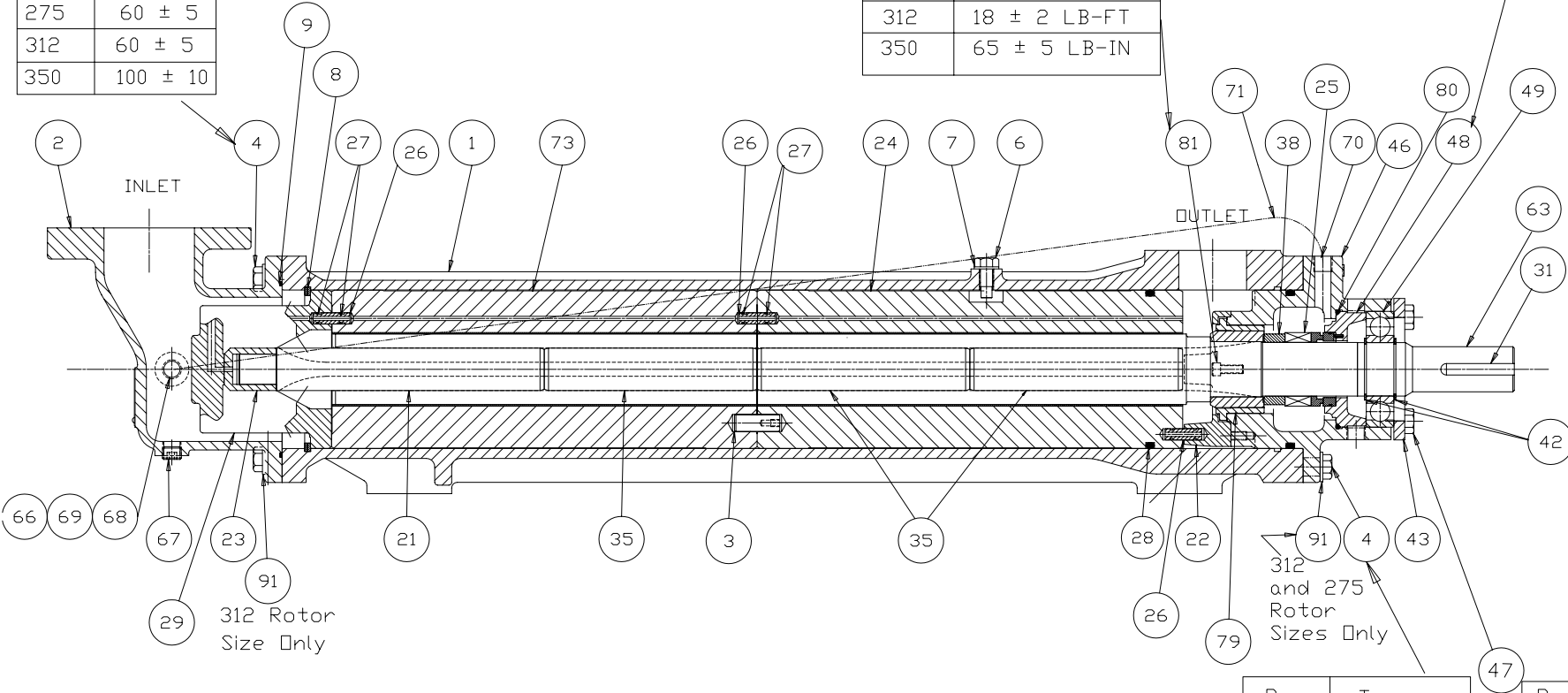

Pump Size	Torque LB-FT
187	90 ± 5
218	165 ± 10
250	220 ± 15
275	110 ± 10
312	150 ± 10
350	180 ± 10

Pump Size	Torque
187	130 ± 10 LB-IN
218	30 ± 2 LB-FT
250	30 ± 2 LB-FT
275	55 ± 5 LB-FT
312	55 ± 5 LB-FT
350	55 ± 5 LB-FT

A AND AK ASSEMBLY DRAWING



ALLWEILER



HOUTTUIN



IMO PUMP



WARREN



A MEMBER OF THE
COLFAX PUMP GROUP

Imo Pump

1710 Airport Road
PO Box 5020
Monroe, NC USA
28111.5020

tel 704.289.6511
fax 704.289.9273
email Imo.Pump@ColfaxCorp.com
web WWW.IMO-PUMP.COM

