

Original Instructions

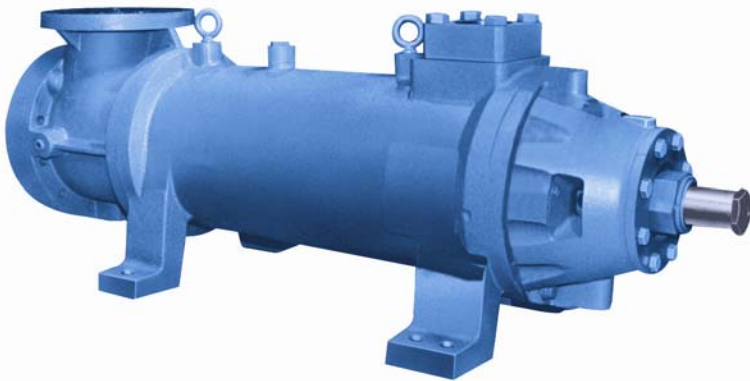

Safety and Operation



WARNING

These instructions should be read thoroughly by all personnel involved with pump operation prior to pump installation, operation, or maintenance.

Manual No. SRM00100

Rev. 01 (12-0064)

February 2012

Contents

A	About this Document	3
	A.1 Target Groups	3
	A.2 Other Applicable Documents	3
	A.3 Warnings and Symbols	4
B.	General Description / Designation / Labeling	5
	B.1 General Description	5
	B.2 Designation	5
	B.3 Labeling	6
C	Safety	7
	C.1 Important Notice	7
	C.2 Operating Instructions of the Operating Party	7
	C.3 Intended Use	7
	C.4 Qualifications of Personnel	8
	C.5 General Safety Instructions	8
	C.6 Installation / Machine Specific Safety Instructions	8
	C.7 Safety Notes on Start-up	8
	C.8 Operation and Maintenance – Safety	9
	C.9 Airborne Noise	9
	C.10 Pumps with Magnetic Coupling	9
D	Transport / Storage	10
	D.1 Safe Lifting and Transportation of Pumps	10
	D.2 Storage / Spare Parts	10
E	Installation / Start-up	11
	E.1 General	11
	E.2 Tools	11
	E.3 Installation / Preheating / Start-up	11
	E.3.1 Lubrication, Preparation	11
	E.3.2 Preheating, Cooling	12
	E.3.3 Mounting / Alignment / Installation	12
	E.3.4 Start-up	12
F	Operation / Shutdown / Restart	13
	F.1 Heating, Cooling During Operation	13
	F.2 Shutdown	13
	F.3 Restarts	14
G	Maintenance	14
	G.1 Performing Maintenance	14
	G.2 Ordering and Installation of Parts / Spare Parts	15
H	Failure	15
I	Troubleshooting	15
J	EC Declaration of Conformity	15

ATTENTION

If operation of this pump is critical to your business, we strongly recommend you keep a spare pump in stock at all times. As a minimum, a seal kit (o-rings, gaskets, and shaft seal) should be kept in stock so pump refurbishment after internal inspection can be accomplished.

A About this Document

This manual:

- Is part of the Imo Pump
- Applies to all Imo Pump models / series
- Provides instructions describing safe and appropriate methods for general installation, operation and trouble shooting of the pump

<i>i</i>	NOTE
<p>Contract terms may have specific provisions which vary from what is shown in this manual! Should any questions arise which are not answered by these instructions, refer to the correct Original Installation, Care and Maintenance Instructions.</p>	



A.1 Target Groups





Target group	Duty
Operating company	<ul style="list-style-type: none"> ➤ Keep this manual available at the site of operation of the equipment, including for later use ➤ Ensure that personnel read and follow the instructions in this manual and the other applicable documents, especially all safety instructions and warnings. ➤ Observe any additional rules and regulations referring to the pump or system.
Specialized Personnel, Fitters, Operators	<ul style="list-style-type: none"> ➤ Read, observe and follow this manual and the other applicable documents, especially all safety instructions and warnings.

A.2 Other Applicable Documents

Document	Purpose
Product Service Manual	Detailed instructions for inspection, disassembly, repair and reassembly of a specific pump model or series.
Original Installation, General Maintenance and Troubleshooting Manual (SRM00101)	Detailed instructions for installation, general maintenance and troubleshooting.
Assembly Drawings, Parts List / Bill-of-Materials	Drawings of the pump assembly and Sub-assemblies Parts List and Bill-of-Materials listing components
ATEX - additional instructions (if applicable)	Operation in explosion-hazard areas
Order Details, data sheet	Technical specifications, conditions of operation
Product Brochures, Engineering Data Sheets	Technical specifications, conditions of operation
Supplier documentation	Technical documentation for parts supplied by subcontractors
Declaration of conformity	Conformity with standards, contents of the declaration of conformity

A.3 Warnings and Symbols

Warning Level	Risk Level	Consequences of disregarding the warning
 DANGER	Immediate Acute Risk	Death, Serious Bodily Harm
 WARNING	Potential Acute Risk	Death, Serious Bodily Harm
 CAUTION	Immediate Hazardous Situation	Minor Bodily Harm, Material Damage
<i>i</i> NOTE	Potentially Hazardous Situation	Minor Bodily Harm, Material Damage

Symbol	Meaning
	Safety Warning Take note of all information highlighted by a Safety Warning Sign and follow the instructions to avoid damage to equipment, injury to personnel or death.
	Instruction
	Multiple Step Instruction
<i>I</i>	Information, Notes
	Strong Magnetic Field – People with pacemakers prohibited within 3 meters
	Electrical Hazard – Contact with water can cause shock. Do NOT touch with wet hands. Always unplug when not in use.



B. General Description / Designation / Labeling

B.1 General Description

B.1.1 Imo 3-Screw General Description

Imo series pumps are single ended or double ended positive displacement, rotary screw pumps consisting of a precision bored housing or housings that enclose a drive screw (power rotor) and two or more intermeshing driven screws (idler rotors). These screws, when rotating, form a succession of closures or cavities. As they rotate, fluid is moved axially from inlet to outlet port in a continuous, uniform flow with minimum fluid pulsation and low pump noise. Fluid flowing through the pump provides lubrication for moving parts.

B.1.2 CIG General Description

The CIG is a positive displacement, internal gear pump. Fluid enters the inlet chamber and is carried across a crescent to the discharge chamber where it is forced out of the stage by the meshing of the internal and external gear teeth. Fluid flowing through the pump provides lubrication to the moving parts. The pump can be multi-staged to increase its pressure capability.

B.2 Designation

This manual applies to all Series of Imo pumps, including all 3-Screw pumps and CIG pumps.

B.2.1 Imo 3-Screw Designation (Except 3G)

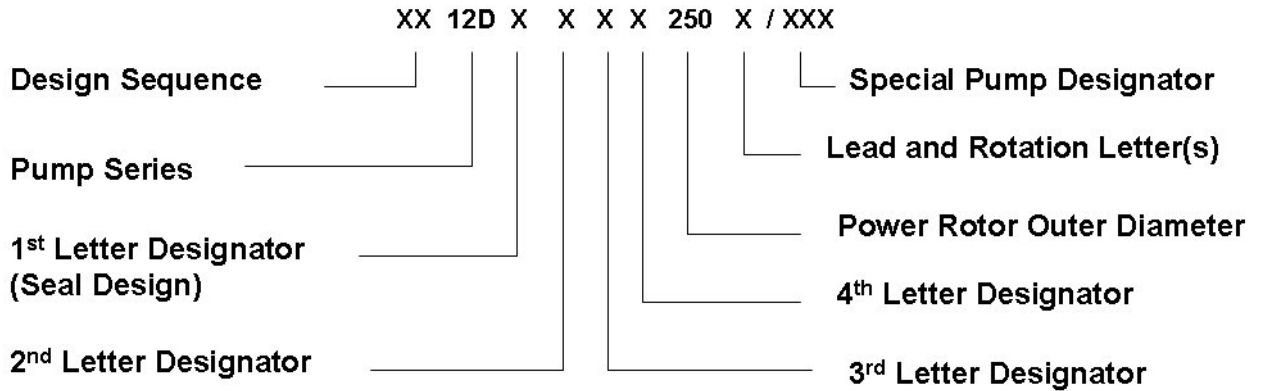

B.2.2 Imo 3-Screw 3G Designation

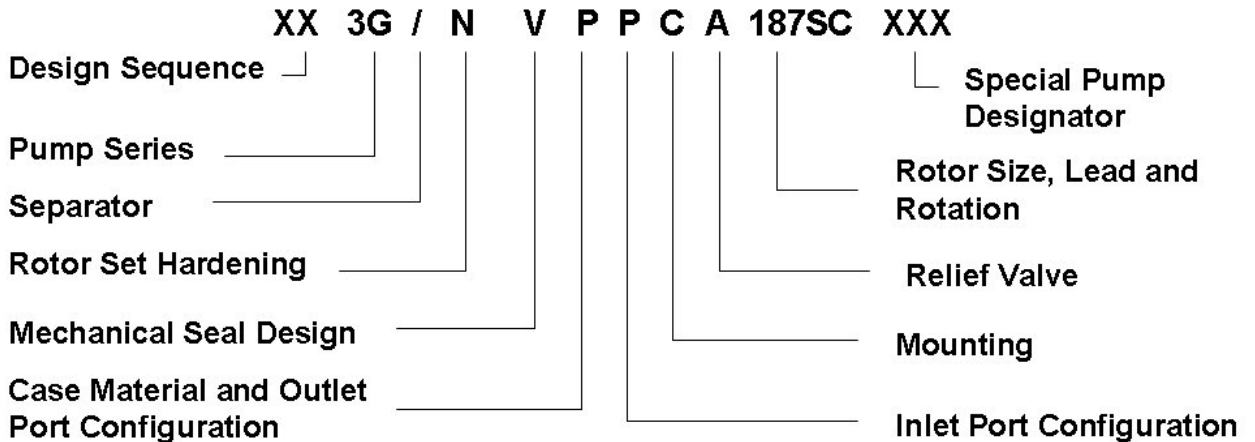

B.2.3 CIG Designation

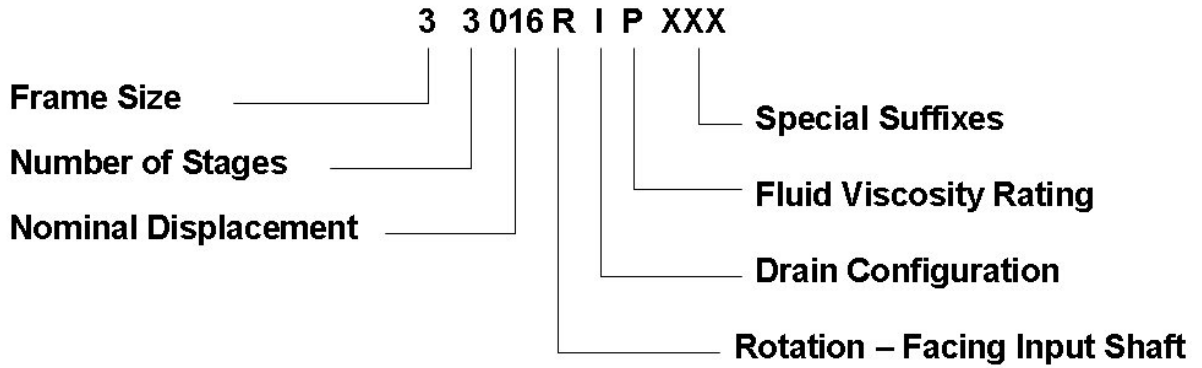

B.2.4 2BIC Designation

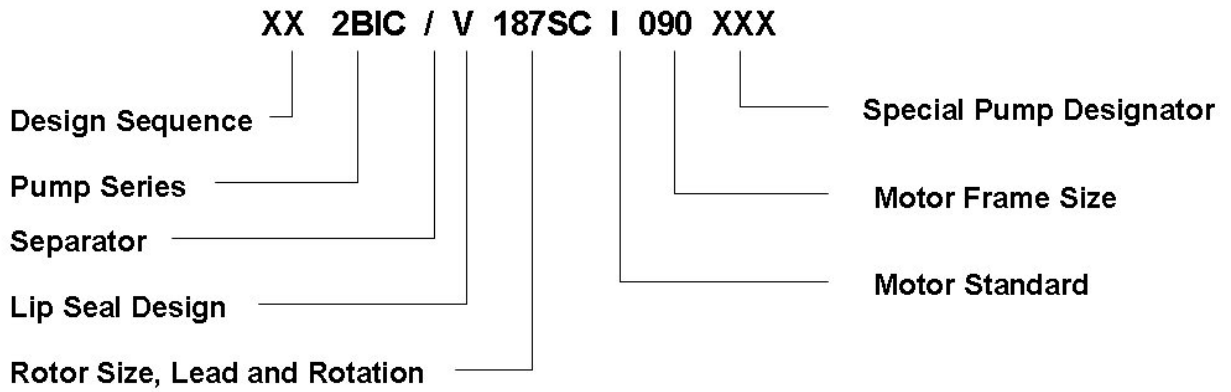

B.3 Labeling

B.3.1 CE Nameplate

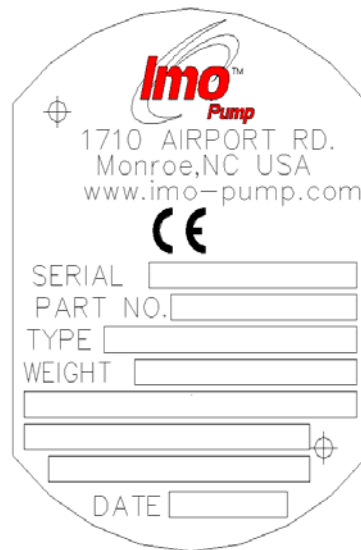

B.3.2 ATEX Nameplate



C Safety

C.1 Important Notice

Read these operating instructions before installation and/or start-up of the pump.



WARNING

Installation, operation, and maintenance instructions must be correctly and strictly followed, else, injury to personnel or serious damage to the pump could result.

Imo Pump cannot accept responsibility for unsatisfactory performance or damage resulting from failure to comply with instructions.

This manual will not cover all situations which might arise with regard to installation, operation, inspection, and maintenance of the equipment supplied. Imo Pump assumes the personnel assigned to install, operate and maintain the supplied equipment have sufficient technical knowledge to apply generally accepted safety and operational practices, which may not be otherwise covered.

Every effort was made to prepare the text of this manual so that technical information is conveyed in easy to understand wording.

C.2 Operating Instructions of the Operating Party

As the operating party, you are responsible for creating specific operating instructions for your personnel based on your company's specific operating conditions. Use this manual to help build your own detailed set of instructions.

C.3 Intended Use



WARNING

Using the pump for processes other than those for which it is intended could result in pump failure or personal harm.

The Imo Pump is a precision device, and is designed to be used as such. If there is a need to operate the pump in a way that is outside the original, published specifications, contact Imo Pump prior to operation for assistance and recommendations.

C.4 Qualifications of Personnel

Only trained operators should be used for start-up and operation of the pump. Only trained, specialized personnel should perform installation, maintenance, disassembly, or reassembly of the pump.

C.5 General Safety Instructions

- Only trained operators or trained, specialized personnel may handle or operate the pump.
- Adhere to the operating limits provided in the Imo specifications or with the order documentation.
- Always wear proper personal protective equipment. (i.e. Safety glasses, steel-toed shoes, face shield, protective clothing, gloves, respirator, dust mask, etc., as required for safe practices)

	CAUTION
Do not run the pump dry, or with no inlet fluid flow. Make sure the pump is only operated with, and never without, liquid filling the pump housing.	

	DANGER
Do not remove safety guards or other protective devices prior to installation or during operation.	

C.6 Installation / Machine Specific Safety Instructions

- Only use the pump as intended, while remaining aware of safety risks, and in adherence to the instructions in this manual.
- Be certain all safety devices, machine safety guards, protective electrical connections, temperature monitoring devices, pressure monitoring devices and sealing apparatus are installed and operation prior to starting the pump.

	CAUTION
Do not operate the pump while the valves in the system are closed.	

- Pumps may not be used with foodstuffs, unless specifically adapted for that purpose. Application for pumping foodstuffs must have been specified in the original purchase order.
- In order to ensure normal functioning of the pump and system, monitor the pressure at the inlet and the outlet of the pump. The monitoring locations should be in the inlet and outlet port connections / flanges, or immediately adjacent to those connections / flanges.
- Monitor the pump temperature, after installation and during operation. Note sudden changes in temperature which do not follow sudden changes in the temperature of the process liquid. If sudden temperature changes of the pump occur, shut down the pump operation and contact trained, specialized personnel for inspection and maintenance.

C.7 Safety Notes on Start-up

- Check to insure that all process safety devices are in place and operational.
- Be certain the pump is fully lubricated and full of fluid prior to starting the motor, and that fluid can and will freely flow into the inlet.
- Be certain the pump temperature has fully reached the process temperature prior to starting the motor. Heat soak the pump sufficiently to ensure all recesses are at process temperature.

- During start-up, start the motor with a low-speed set point if possible, then gradually increase speed to the intended operating speed. An acceleration rate of 200 rpm / sec or less is recommended; 50 rpm / sec is best, allowing ample acceleration time for downstream apparatus to fill gradually with fluid, and for pressure to rise slowly.

C.8 Operation and Maintenance – Safety

<i>i</i>	NOTE
The manufacturer's warranty will be void if any part is replaced, or the pump is modified in any way, without permission from Imo Pump.	

	DANGER
Dead-head condition occurs when there is a blockage upstream and the pump attempts to reach the maximum pressure achievable at a given speed, with a given fluid viscosity.	
Reaching the dead-head condition may cause the pump to fail, or for piping limits to be exposed.	

	WARNING
Downstream pressure can change rapidly once the pump is started. If the downstream flow passages are blocked or valves are closed, the pump will likely reach dead-head condition before valves can be opened or the blockage removed.	

<i>i</i>	NOTE
Only trained, specialized personnel are qualified to perform maintenance, which includes, but is not limited to:	
<ul style="list-style-type: none"> ○ Inspection ○ Repair ○ Assembly ○ Disassembly 	
Contact Imo Pump for information on training personnel.	



Measure the pump temperature after installation, and monitor temperature during operation. Rapid changes in temperature, while process temperatures and ambient temperatures are stable, signals a pending failure. Make use of every provided temperature measurement connection point, i.e. thermocouple mounting points, etc.

C.9 Airborne Noise

- Airborne noise levels will be less than or equal to 70 dBA unless otherwise stated in the individual pump Product Service Manual.

C.10 Pumps with Magnetic Coupling

Magnetic couplings use strong permanent-magnets, which generate a strong magnetic field. The installation must be carried out only by trained, specialized personnel. All installation instructions must be strictly followed. Modifications or changes to the magnetic coupling, or its components, are not allowed. The manufacturer does not take responsibility for damage caused by improper use.

	DANGER
	<p>In areas where permanent magnetic couplings are handled or stored with open access, persons with heart pacemakers should keep a safety distance of 3 meters. For permanent magnetic couplings assembled within a pump a safety distance of 1 meter is sufficient.</p> <ul style="list-style-type: none"> ○ Installation and maintenance must be performed by trained, specialized personnel, and must always take place during complete shutdown in an un-pressurized condition. The drive unit must be secured against switching-on (with signs, switching off electricity to power supply,) in order to avoid serious injuries. ○ Danger of crushing! Do not reach inside the working area during the operation of the coupling. For protection against accidental contact, appropriate machine guards must be installed and security must be maintained.

	CAUTION
<p>Magnetic data carriers (bank cards, hard drives and other electronic devices) may become unreadable and should be kept away from the magnetic field of the magnetic coupling.</p>	

D Transport / Storage

D.1 Safe Lifting and Transportation of Pumps

	DANGER
<p>Death or crushing of limbs caused by falling or overturning loads!</p>	

	WARNING
<p>Bodily harm can occur if excessive weight is lifted or moved incorrectly!</p>	

	WARNING
<p>Protection from hot surfaces and hot liquids must be provided by the operator!</p>	

Take care not to drop the pump. Pump weights are clearly and durably marked onto the pump surface. Read and consider the weight prior to attempting to lift or move the pump. Do not attempt to lift pumps heavier than 25 kg without the use of a crane or other type of lifting assist device. Only qualified personnel may transport pumps weighing more than 25 kg.

When working with pumps that are hot, wear proper protective equipment and note that hot fluid may flow from the pump. Guard against skin contact with hot fluids, or with a hot pump. Follow all precautions of the fluid manufacturer in the handling of the fluid.

D.2 Storage / Spare Parts

In the event that an Imo Pump needs to be stored, always protect the pump against water and other contaminants. Store the pump in a clean, dry, and warm environment. Pumps are delivered with ISO 32, PL-2, or other suitable lubricant (unless specifically prohibited on the customer order,) and with protective covers in, or over, all openings. These covers should remain in place during the mounting and alignment procedures, as long as possible. Remove the covers just prior to attaching system piping to the pump. If the pump is to be stored at an elevated temperature or in a challenging environment, or if they are to be stored for more than six months, contact Imo Pump for appropriate storage procedures.

While storing spare parts, always protect the parts from water and contaminants. Store the parts in a clean, dry, and warm environment. Spare parts should be lightly coated with rust preventative oil and sealed in an air tight container.

E Installation / Start-up

E.1 General



Only trained, specialized personnel can correctly perform installation and start-up of Imo pumps.

Pumps should be carefully unpacked to make sure that the shipment is complete. If any items are missing or damaged, the freight carrier and Imo should be notified immediately.

While the pump is composed of steel or other durable metal, it is a precision instrument. Dropping the pump, or striking it with a hard material, can cause serious damage to the components. Many pump materials are through-hardened to maximum hardness, resulting in a brittle condition. Treat them as you would any precision gauging instrument.

	CAUTION
Do not run the pump dry or with no inlet fluid flow. Make sure the pump is only operated with, and never without, liquid filling the pump housing.	

	WARNING
On critical or dangerous equipment, provide safety and emergency systems to protect personnel and property from injury due to pump malfunction. If pumped liquids are flammable, toxic, corrosive, explosive or otherwise hazardous, provide for safety in the event of leakage or malfunction.	

	DANGER
	BEFORE working on equipment, all power to equipment must be disconnected and locked-out.

E.2 Tools

The procedures mentioned in this manual may require mechanic's hand tools, dial indicators and straight-edges for alignment, suitable lifting devices such as slings or straps, lifting-assist devices or pry-bars.

If the pump is made from softer materials, such as bronze, nickel, or titanium alloys or austenitic stainless steels, the tools used should be brass or copper, in order to prevent damaging the pump.

E.3 Installation / Preheating / Start-up

	WARNING
If at any time during operation the pump does not appear to be running smoothly, or unusual noise is heard, stop the pump immediately, to limit internal damage, and contact Imo.	

E.3.1 Lubrication, Preparation

Imo pumps are shipped filled with ISO 32, PL-2, or other rust preventative lubricant as specified. If no special requirements are noted, the lubricant is ISO 32 or PL-2.

When readying the pump for service, determine whether the lubricant in the pump is suitable for introduction into the process. Additional information on ISO 32 or PL-2 can be found at www.imopump.com or by contacting Imo Pump.



WARNING

It is important the lubricant does not leave carbon residue when heated and evaporated. All organic oils and many synthetic oils will leave carbon residue when evaporation occurs. Carbon residue has the appearance of a baked-on, enamel finish, and has the same effect as if a strong adhesive was introduced into the pump.

Drain the excess fluid from the Imo Pump, and flush the lubricant if there are concerns about contamination of the process line, or if there are concerns about use of the lubricant at operating temperature. After flushing, the pump must be lubricated internally. Pour a process-compatible, temperature-compatible lubricant into the inlet port and turn the pump drive shaft by hand until the lubricant flows from the discharge port.

E.3.2 Preheating, Cooling



WARNING

- Do not allow the pump to change temperature rapidly.
- Do not apply open flame to a pump.
- Do not allow leaking fluid to catch fire.
- Do not expose the pump to liquid nitrogen or other extremely cold substances.
- Do not attempt to quench a hot pump by applying water or other cool liquid to the surface.

If the pump is to be preheated or cooled prior to installation, heat or cool the pump to the operating temperature by use of an approved method, such as a band heater, bar heater, oven, cooling or environmental chamber, liquid bath or heating jacket, which can fully reach the operating temperature of the pumping system. Monitor the pump temperature and ensure the target temperature has been met and maintained. Allow ample time to heat-soak the pump thoroughly and evenly (including the seal arrangement).

E.3.3 Mounting / Alignment / Installation

Mounting, alignment and installation of the pump should only be performed by trained, specialized personnel in conjunction with the appropriate Original Installation, Care and Maintenance Instructions.

E.3.4 Start-up

Consult the Installation, General Maintenance and Troubleshooting Manual (SRM00101) for full start-up instructions.



WARNING

If operating temperatures exceed 60°C (140°F), measures must be taken to avoid skin contact.

- ↻ Flush out the plumbing system before connecting the pump.
- ↻ Fluid entering the pump should be filtered to limit particle size to ½ the rotor clearances in the pump during operation. Consult the factory.
- ↻ Rotate the pump drive shaft by hand after mounting and fully tightening the mounting bolts. The shaft should turn easily.

- ↻ Make sure fluid freely enters the pump before starting. Be sure to apply sufficient positive inlet pressure to prevent cavitation during operation. Be sure inlet valves are open.
- ↻ Be certain all guards and safety apparatus are installed completely prior to start-up.
- ↻ Connect all pressure monitoring and temperature monitoring equipment and confirm they are functioning correctly.
- ↻ Be certain all down-stream valves, etc., are open.
- ↻ Start motor at the intended operating speed. Slowly close the downstream valves to allow for gradual pressure rise.
- ↻ If the pump uses Packing seals:

<i>I</i>	NOTE
Slight leakage is necessary to lubricate the packing during operation.	

	WARNING
If not appropriately collected, packing leakage may make floor slippery and/or expose personnel to hazardous fluids. Collect packing leakage properly and safely.	

- Tighten the packing follower screws in a crossing pattern, gradually, until the packing is evenly compressed and the leakage diminishes to near zero, then loosen each of the screws, gradually, ¼ turn at a time, until slight leakage occurs. Slight leakage is necessary in order to lubricate the packing and the shaft.
 - ↻ Be certain to adjust the packing follower properly.
 - ↻ Do not over-tighten the packing follower. Over-tightening will cause damage to the packing and the shaft.
 - ↻ Other sealing options are available.
- Re-adjust the packing follower several times through the running-in period, until the seal is thoroughly seated and the rate of leakage is stable.

F Operation / Shutdown / Restart

F.1 Heating, Cooling During Operation

If the pump is to be operated outside of room temperature (10°C – 45°C), care must be taken to ensure the process temperature is met and maintained prior to and during operation. Monitor the pump temperature and ensure the target temperature has been met and maintained. Allow ample time for the pump to adjust and stabilize. Ensure any temperature changes occur gently, thoroughly and evenly (including the seal arrangement).

Protect the pump from thermal shocks of greater than 28°C (50°F) / sec. This could occur from liquid entering the pump, from rapid changes in the temperature of the environment or from fire. Rapid temperature changes must be avoided. Preheating is required when a pump's operating temperature is greater than 28°C (50°F) above ambient temperature.

F.2 Shutdown

The pump may need to be purged of the process fluid during shutdown. Use of a purging liquid (an inert, lubricating liquid which is safe to the pump and personnel,) is recommended, rather than simply attempting to drain the process fluid from the pump.

- ↻ Run the pump slowly during the purging process in order to ensure no damage occurs.

- ↺ Separate the coupling components, connecting the pump shaft to the gearbox or motor, and turn the pump by hand, or with a wrench, when completing the purging and draining.
- ↺ If no purging liquid is available, and the pump will be run in order to facilitate draining, be cautious to complete the operation in less than 1 minute.
- ↺ If the pump is to be stored, or if it will sit for a long period without operation or protection, apply rust preventative oil to all internal and external surfaces.

F.3 Restarts

On restart, follow the procedures for start up, from previous section.

	CAUTION
<p>Take care the product has not changed properties. Ensure the fluid is still capable of providing lubrication to the pump internal components. Restart slowly and gradually.</p>	

G Maintenance

G.1 Performing Maintenance

	WARNING
<p>Seal failure will eventually occur. Develop a plan to deal with this situation. Take appropriate safety measures if liquid is hazardous.</p>	

	WARNING
<p>BEFORE starting any maintenance procedure, do the following:</p> <ul style="list-style-type: none"> ↺ Shut off all power switches and circuit breakers. ↺ Remove any electrical service fuses. ↺ Lock electrical service panel supplying power to driver. ↺ Shut, wire or chain, and lock all valves in pump inlet/outlet piping ↺ If applicable, shut off any steam or other fluid supply lines to the pump. 	

Visually check equipment frequently for signs of damage or leakage from shaft seals, gaskets or O-rings. Be sure all connections are tight. If seal leakage is more than about 10 drops per hour per seal, shut down equipment and repair or replace necessary parts. Shaft seals have a limited, finite life which is affected by operating conditions and environment. Expect them to wear and eventually fail. When leakage becomes unacceptable, replace the seal unit with the correct replacement unit, one compatible with pump's operating conditions. Dirty liquids will reduce seal life.

Packing seals should be replaced when all packing follower travel is exhausted or when packing is damaged and leakage cannot be controlled.

Where pump out-of-service time is of vital concern and down-time must be minimized, kits of spare parts and seals should be acquired before needed and retained on-site.

Only trained, specialized personnel, using the appropriate Original Installation, Care and Maintenance Instructions, can perform maintenance, which includes, but is not limited to, Inspection, Repair, Assembly and Disassembly.

Contact Imo Pump for information on having personnel trained.

G.2 Ordering and Installation of Parts / Spare Parts

When contacting Imo Pump regarding replacement parts, be prepared to provide the pump's markings and the assembly drawing as instructed below:

- ↳ From the markings on the pump, record the pump model number, serial number and weight.
- ↳ From the assembly drawing or instruction manual, provide the names for the replacement part(s).
- ↳ Give the above information to your Imo service representative.

Installation of spare parts should only be performed by trained, specialized personnel in conjunction with the appropriate Original Installation, Care and Maintenance Instructions.

H Failure

All failures can be investigated and serviced through Imo Pump's repair or warranty service departments.

I Troubleshooting

Troubleshooting should be done by trained, specialized personnel in conjunction with the General Maintenance and Troubleshooting Manual (SRM00101). Imo Pump can also be contacted with assistance in troubleshooting.

J EC Declaration of Conformity

EC Declaration of Conformity is included with the documents provided with the pump

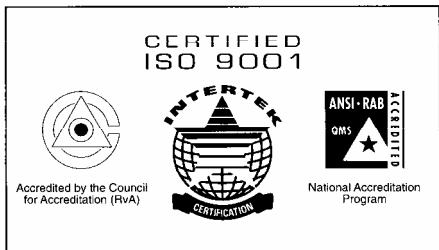

COLFAX CORPORATION

Imo Pump

1710 Airport Road
Monroe, NC USA
28110

tel 704.289.6511

email customercare@colfaxcorp.com

web www.lmopump.com

COLFAX, ALLWEILER, BARIC, COLFAX BUSINESS SYSTEM, FAIRMOUNT AUTOMATION, HOUTTUIN, Imo, LSC, ROSSCOR, TUSHACO, WARREN and ZENITH are registered trademarks of the Colfax Corporation or its subsidiaries in the U.S. and/or other countries.

©2011 Colfax Corporation. All rights reserved.